

CHAPTER-1

CLASSIFICATION OF RADIO TRANSMITTERS ACCORDING TO THE TYPE OF SERVICE INVOLVED:

1) Radio Telegraph Transmitters: A radio telegraph transmitter transmits telegraph signals from one radio station to another radio station. It may use either amplitude modulation or frequency modulation. When point-to-point radio communication is involved, the transmitting antennas are highly directive so that the electromagnetic energy is beamed into a narrow beam directed towards the receiving antenna at the receiving radio station.

2) Television Transmitters: Television broadcast requires two transmitters one for transmission of picture and the other for transmission of sound. Both operate in very high frequency of in ultra-high frequency range. The picture transmitter is amplitude modulated by the picture signal occupying a band of about 5 MHz Vestigial transmission is used i.e. one full sideband and only a vestige or a part (about 0.75 MHz) of the other sideband together with the carrier are radiated from the transmitting aerial. The total bandwidth occupied by one television channel is about 7 MHz The sound carrier is frequency modulated.

3) Radar Transmitter: Radar (abbreviation for Radio Detection and Ranging) may be of two types:

(i) Pulse Radar and (ii) C.W. (Continuous Wave Radar).

Pulse radar transmitter uses pulse modulation of carrier. It uses high output power typically 100 kW peak and operates at microwave frequencies typically 3000 MHz (10 cm wavelength) or 10,000 MHz (3 cm wavelength). The C.W. radar transmitter may use frequency modulation of the carrier voltage or may utilize Doppler Effect.

4) Navigation Transmitters: A number of navigational aids using special types of radio transmitters and receivers are used these days for sea and air navigation. Also radio aids are used for blind landing of aircrafts. Typical radio aids of landing are (a) I.L.S. (Instrumental Landing System) and (b) G.C.A. (Ground Controlled Approach). In addition to these, several other radio means are provided at airport for surveillance. Accordingly, a large number of radio transmitter of varied types, frequency and power are required depending upon the operation desired.

CLASSIFICATION OF RADIO TRANSMITTERS ACCORDING TO THE CARRIER FREQUENCY

1) Long Wave Transmitters: These transmitters operate on long waves i.e. on frequencies below 300 kHz. Such long wave radio transmitters are used for broadcast in temperate countries, where atmospheric disturbances on long waves are not severe. Since long wave radio signals travel along the surface of earth and are rapidly attenuated, for reasonably high signal strength at the distant receiving aerial, the carrier power radiated from the transmitting aerial must be very large typically 100 kW or more.

2) Medium Wave Transmitters: These transmitters operate on frequencies in the range of 550 to 1650 kHz and are usually used for broadcast. Hence the band of frequency extending from 550 to 1650 kHz is commonly referred to as the Broadcast Band. The carrier power may vary from as low as 5 kW to as high as 500 to 1000kW.

3) Short Wave Transmitters: These transmitters operate on frequencies in the short wave range of 3 to 30MHz. In practice, frequencies beyond 24 MHz' are not used. Ionosphere propagation of electromagnetic waves takes place at such short waves. The attenuation of radio waves travelling from the transmitting aerial to the distant receiving aerial though the ionosphere is small Hence carrier power required to be radiated from the transmitting aerial is small. For national broadcast the carrier power used may vary from about 1 to 10 kW For overseas broadcast certain amount of beaming of power is required to be done But in spite of such a beaming of energy; because of the large distance involved, the carrier power generally used is 10 to 1 00 kW. For radio telephone working over long distances on short waves, highly directive transmitting and receiving antennas are used so that carrier power required may be relatively small; of the order of 5 kW or so.

Block diagram of AM transmitter with explanation

AM Transmitter:

Transmitters that transmit AM signals are known as AM transmitters. These transmitters are used in medium wave (MW) and short wave (SW) frequency bands for AM broadcast. The MW band has frequencies between 550 KHz and 1650 KHz, and the SW band has frequencies ranging from 3 MHz to 30 MHz The two types of AM transmitters that are used based on their transmitting powers are:

- High Level
- Low Level

High level transmitters use high level modulation, and low level transmitters use low level modulation. The choice between the two modulation schemes depends on the transmitting power of the AM transmitter. In broadcast transmitters, where the transmitting power may be of the order of kilowatts, high level modulation is employed. In low power transmitters, where only a few watts of transmitting power are required, low level modulation is used.

High-Level and Low-Level Transmitters

Below figures show the block diagram of high-level and low-level transmitters. The basic difference between the two transmitters is the power amplification of the carrier and modulating signals.

Figure (a) shows the block diagram of high-level AM transmitter.

In high-level transmission, the powers of the carrier and modulating signals are amplified before applying them to the modulator stage, as shown in figure (a). In low-level modulation, the powers of the two input signals of the modulator stage are not amplified. The required transmitting power is obtained from the last stage of the transmitter, the class C power amplifier.

The various sections of the figure (a) are:

- Carrier oscillator
- Buffer amplifier
- Frequency multiplier
- Power amplifier
- Audio chain
- Modulated class C power amplifier

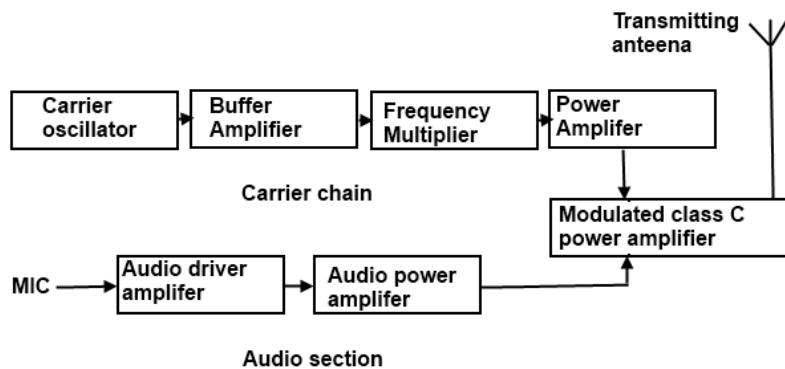

Figure (a) Block diagram of high level AM transmitter

Carrier oscillator

The carrier oscillator generates the carrier signal, which lies in the RF range. The frequency of the carrier is always very high. Because it is very difficult to generate high frequencies with good frequency stability, the carrier oscillator generates a sub multiple with the required carrier frequency. This sub multiple frequency is multiplied by the frequency multiplier stage to get the required carrier frequency. Further, a crystal oscillator can be used in this stage to generate a low frequency carrier with the best frequency stability. The frequency multiplier stage then increases the frequency of the carrier to its required value.

Buffer Amplifier

The purpose of the buffer amplifier is twofold. It first matches the output impedance of the carrier oscillator with the input impedance of the frequency multiplier, the next stage of the carrier oscillator. It then isolates the carrier oscillator and frequency multiplier.

This is required so that the multiplier does not draw a large current from the carrier oscillator. If this occurs, the frequency of the carrier oscillator will not remain stable.

Frequency Multiplier

The sub-multiple frequency of the carrier signal, generated by the carrier oscillator, is now applied to the frequency multiplier through the buffer amplifier. This stage is also known as harmonic generator. The frequency multiplier generates higher harmonics of carrier oscillator frequency. The frequency multiplier is a tuned circuit that can be tuned to the requisite carrier frequency that is to be transmitted.

Power Amplifier

The power of the carrier signal is then amplified in the power amplifier stage. This is the basic requirement of a high-level transmitter. A class C power amplifier gives high power current pulses of the carrier signal at its output.

Audio Chain

The audio signal to be transmitted is obtained from the microphone, as shown in figure (a). The audio driver amplifier amplifies the voltage of this signal. This amplification is necessary to drive the audio power amplifier. Next, a class A or a class B power amplifier amplifies the power of the audio signal.

Modulated Class C Amplifier

This is the output stage of the transmitter. The modulating audio signal and the carrier signal, after power amplification, are applied to this modulating stage. The modulation takes place at this stage. The class C amplifier also amplifies the power of the AM signal to the required transmitting power. This signal is finally passed to the antenna, which radiates the signal into space of transmission.

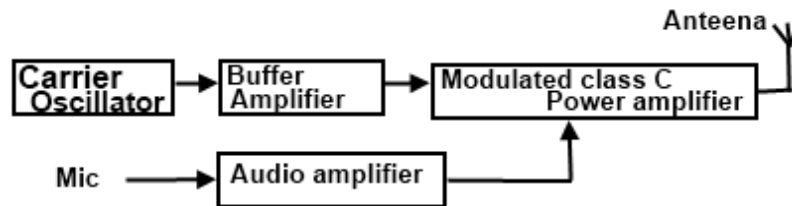

Figure (b) Block diagram of Low-level AM transmitter

Figure shows the block diagram of a low-level AM transmitter.

The low-level AM transmitter shown in the figure (b) is similar to a high-level transmitter, except that the powers of the carrier and audio signals are not amplified. These two signals are directly applied to the modulated class C power amplifier.

Modulation takes place at the stage, and the power of the modulated signal is amplified to the required transmitting power level. The transmitting antenna then transmits the signal.

FM transmitter

The following image shows the block diagram of the FM transmitter and the required components of the FM transmitter are; microphone, audio pre amplifier, modulator, oscillator, RF- amplifier and antenna. There are two frequencies in the FM signal, first one is carrier frequency and the other one is audio frequency. The audio frequency is used to modulate the carrier frequency. The FM signal is obtained by differing the carrier frequency by allowing the AF. The FM transmitter consists of oscillator to produce the RF signal.

Block Diagram of FM Transmitter

Working of FM Transmitter Circuit

The following circuit diagram shows the FM transmitter circuit and the required electrical and electronic components for this circuit is the power supply of 9V, resistor, capacitor, trimmer capacitor, inductor, mic, transmitter, and antenna. Let us consider the microphone to understand the sound signals and inside the mic there is a presence of capacitive sensor. It produces according to the vibration to the change of air pressure and the AC signal.

The formation of the oscillating tank circuit can be done through the transistor of 2N3904 by using the inductor and variable capacitor. The transistor used in this circuit is an NPN transistor used for general purpose amplification. If the current is passed at the inductor L1 and variable capacitor, then the tank circuit will oscillate at the resonant carrier frequency of the FM modulation. The negative feedback will be the capacitor C2 to the oscillating tank circuit.

To generate the radio frequency carrier waves the FM transmitter circuit requires an oscillator. The tank circuit is derived from the LC circuit to store the energy for oscillations. The input audio signal from the mic penetrated to the base of the transistor, which modulates the LC tank circuit carrier frequency in FM format. The variable capacitor is used to change the resonant frequency for fine modification to the FM frequency band. The modulated signal from the antenna is radiated as radio waves at the FM frequency band and the antenna is nothing but copper wire of 20cm long and 24 gauge. In this circuit the length of the antenna should be significant and here you can use the 25-27 inches long copper wire of the antenna.

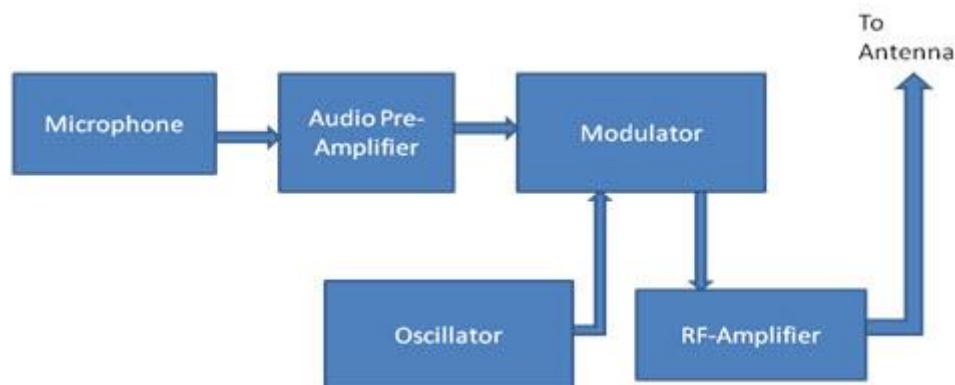

CHAPTER-2

Super heterodyne receiver circuit blocks

There are some key circuit blocks that form the basic super heterodyne receiver. Although more complicated receivers can be made, the basic circuit is widely used – further blocks can add improved performance or additional functionality and their operation within the whole receiver is normally easy to determine once the basic block diagram is understood.

- **RF tuning & amplification:** This RF stage within the overall block diagram for the receiver provides initial tuning to remove the image signal. It also provides some amplification. If noise performance for the receiver is important, then this stage will be designed for optimum noise performance. This RF amplifier circuit block will also increase the signal level so that the noise introduced by later stages is at a lower level in comparison to the wanted signal.
- **Local oscillator:** The local oscillator circuit block can take a variety of forms. Early receivers used free running local oscillators. Today most receivers use frequency synthesizers, normally based around phase locked loops. These provide much greater levels of stability and enable frequencies to be programmed in a variety of ways.
- **Mixer:** Both the local oscillator and incoming signal enter this block within the super heterodyne receiver. The wanted signal is converted to the intermediate frequency.
- **IF amplifier & filter:** This super heterodyne receiver block provides the majority of gain and selectivity. High performance filters like crystal filters may be used, although LC or ceramic filters may be used within domestic radios.
- **Demodulator:** The super heterodyne receiver block diagram only shows one demodulator, but in reality radios may have one or more demodulators dependent upon the type of signals being receiver.
- **Audio amplifier:** Once demodulated, the recovered audio is applied to an audio amplifier block to be amplified to the required level for loudspeakers or headphones. Alternatively, the recovered modulation may be used for other

applications whereupon it is processed in the required way by a specific circuit block.

Super heterodyne receiver block diagram explanation

Signals enter the receiver from the antenna and are applied to the RF amplifier where they are tuned to remove the image signal and also reduce the general level of unwanted signals on other frequencies that are not required.

The signals are then applied to the mixer along with the local oscillator where the wanted signal is converted down to the intermediate frequency. Here significant levels of amplification are applied and the signals are filtered. This filtering selects signals on one channel against those on the next. It is much larger than that employed in the front end. The advantage of the IF filter as opposed to RF filtering is that the filter can be designed for a fixed frequency. This allows for much better tuning. Variable filters are never able to provide the same level of selectivity that can be provided by fixed frequency ones.

Once filtered the next block in the super heterodyne receiver is the demodulator. This could be for amplitude modulation, single sideband, frequency modulation, or indeed any form of modulation. It is also possible to switch different demodulators in according to the mode being received.

The final element in the super heterodyne receiver block diagram is shown as an audio amplifier, although this could be any form of circuit block that is used to process or amplified the demodulated signal.

Block diagram summary

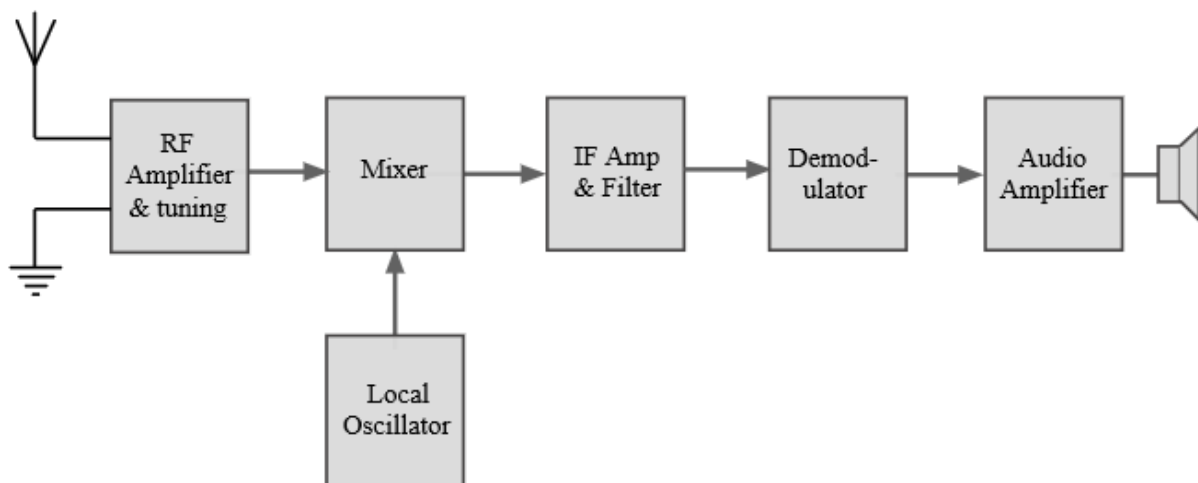

The diagram above shows a very basic version of the superhot or super heterodyne receiver. Many sets these days are far more complicated. Some superhot radios have more than one frequency conversion, and other areas of additional circuitry to provide the required levels of performance.

However, the basic super heterodyne concept remains the same, using the idea of mixing the incoming signal with a locally generated oscillation to convert the signals to a new frequency

The parameters of the AM Receivers Are Sensitivity, Selectivity, Fidelity, Image frequency rejection etc. some of which are explained below:

1. Selectively

- The selectivity of an AM receiver is defined as its ability to accept or select the desired band of frequency and reject all other unwanted frequencies which can be interfering signals.
- Adjacent channel rejection of the receiver can be obtained from the selectivity parameter.
- Response of IF section, mixer and RF section considerably contribute towards selectivity.
- The signal bandwidth should be narrow for better selectivity.

- Graphically selectivity can be represented as a curve shown in Fig1. Below, which depicts the attenuation offered to the unwanted signals around the tuned frequency.

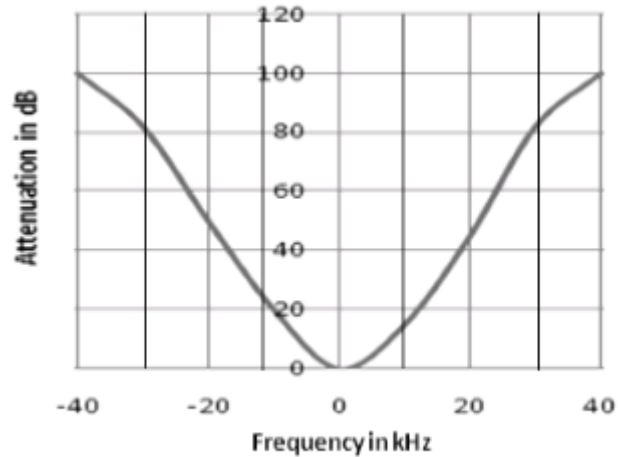

Fig1. Selectivity curve

2. Fidelity

- Fidelity of a receiver is its ability to reproduce the exact replica of the transmitted signals at the receiver output.
- For better fidelity, the amplifier must pass high bandwidth signals to amplify the frequencies of the outermost sidebands, while for better selectivity the signal should have narrow bandwidth. Thus a tradeoff is made between selectivity and fidelity.
- Low frequency response of IF amplifier determines fidelity at the lower modulating frequencies while high frequency response of the IF amplifier determines fidelity at the higher modulating frequencies.

3. Sensitivity

- Sensitivity of a receiver is its ability to identify and amplify weak signals at the receiver output.
- It is often defined in terms of voltage that must be applied to the input terminals of the receiver to produce a standard output power which is measured at the output terminals.

- The higher value of receiver gain ensures smaller input signal necessary to produce the desired output power.
- Thus a receiver with good sensitivity will detect minimum RF signal at the input and still produce utilizable demodulated signal.
- Sensitivity is also known as receiver threshold.

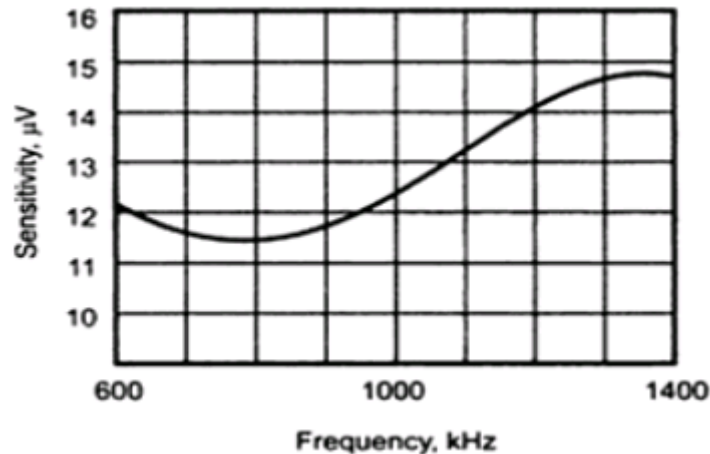

- It is expressed in microvolts or decibels.
- Sensitivity of the receiver mostly depends on the gain of IF amplifier.
- It can be improved by reducing the noise level and bandwidth of the receiver.
- Sensitivity can be graphically represented as a curve shown in Fig2. Below, which depicts that sensitivity varies over the tuning band.

Fig2. Sensitivity curve

4. Double spotting

- Double spotting is a condition where the same desired signal is detected at two nearby points on the receiver tuning dial.
- One point is the desired point while the other is called the spurious or image point.
- It can be used to determine the IF of an unknown receiver.
- Poor front-end selectivity and inadequate image frequency rejection leads to double spotting.
- Double spotting is undesirable since the strong signal might mask and overpower the weak signal at the spurious point in the frequency spectrum.

- Double spotting can be counter acted by improving the selectivity of RF amplifier and increasing the value of IF.
- Consider an incoming strong signal of 1000 kHz and local oscillator tuned at 1455 kHz. Thus a signal of 455 kHz is produced at the output of the mixer which is the IF frequency.

Now consider the same signal but with 545 kHz tuned local oscillator. Again we get 455 kHz signal at the output.

Therefore, the same 1000 kHz signal will appear at 1455 kHz as well as 545 kHz on the receiver dial and the image will not get rejected. This is known as Double spotting phenomenon.

- It is also known as adjacent channel selectivity.

In radio, the **image rejection ratio**, or image frequency rejection ratio, is the ratio of (a) the intermediate-frequency (IF) signal level produced by the desired input frequency to (b) that produced by the image frequency. The image rejection ratio is usually expressed in dB when the image rejection ratio is measured, the input signal levels of the desired and image frequencies must be equal for the measurement to be meaningful.

Selection of IF freq.

The choice of an IF frequency is one of those design trade-offs.

The lower the IF frequency used, the easier it is to achieve a narrow bandwidth to obtain good selectivity in the receiver and the greater the IF stage gain. On the other hand, the higher the IF, the further removed the image frequency is from the signal frequency and hence the better the image rejection.

One problem of the problems of a super heterodyne receiver, is its ability to pick up a second or image frequency that is twice the intermediate frequency away from the signal frequency.

For example, if we have a signal frequency of 1 MHz which is mixed with an IF of 455 kHz. A second or image signal, with a frequency equal to 1 MHz plus (2 x 455) kHz or 1.910 MHz, can also mix with the 1.455 MHz to produce the 455 kHz.

The choice of IF is also affected by the selectivity of the RF end of the receiver. If the receiver has a number of RF stages, it is better able to reject an image signal close to the signal frequency and hence a lower IF channel can be tolerated. This is why modern rigs have 2 or even 3 IF stages.

The chosen IF frequency should be free from radio interference. Standard intermediate frequencies have been established and these are kept clear of signal channel allocation.

As you have noted, 455 KHz is a common IF. This is because broadcasters settled on this as a standard frequency during the broadcast AM days.

From a design point of view 455KHz it leads to poor image response when used above 10 MHz One commonly used IF for shortwave receivers is 1.600 MHz and this gives a much improved image response for the HF spectrum. Ham band SSB HF transceivers have commonly used 9 MHz as a receiver intermediate frequency

This frequency is a little high for ordinary tuned circuits to achieve the narrow bandwidth needed in speech communication, however, when used with ceramic crystal filter networks it leads to good results.

Some recent amateur transceivers use intermediate frequencies slightly below 9 MHz A frequency of 8.830 MHz can be found in various Kenwood transceivers and a frequency of 8.987.5 MHz in some Yaesu transceivers. This change could possibly be to avoid the second harmonic of the IF falling too near the edge of the 17m WARC band

Simple & Delayed AGC

Automatic gain control (AGC) is a mechanism wherein the overall gain of the radio receiver is automatically varied according to the changing strength of the received signal. This is done to maintain the output at a constant level. If the gain is not varied as per the input signal, consider a stronger input signal, then the signal might probably be distorted with some of the amplifiers reaching saturation level. AGC is applied to the RF, IF and mixer stages, which also helps in improving the dynamic range of the receiver antenna to 60-100 dB by adjusting the gain of the various stages in the radio receiver. The AGC derives dc bias voltage from the part of the detected signal to apply to the RF, IF and mixer stages to control their gains. The Trans conductance and hence the gain of the devices used in these stages of the receiver depends on the applied bias voltage or current. When the overall signal level increases, the value of the applied AGC bias increase leading to the

decrease in the gain of the controlled stages. When there is no signal or signal with low value, there is minimum AGC bias which results in amplifier generating maximum gain. AGC facilitates tuning to varying signal strength stations providing a constant output. AGC smoothens the amplitude variations of the input signal and the gain control does not have to be recalibrated every time the receiver is tuned from station to station. An AGC which is not designed correctly can lead to considerable distortion to a smooth signal.

There are two types of AGC circuits:

- Simple AGC: the gain control mechanism is active for high as well as low value of carrier voltage.
- Delayed AGC: AGC bias is not applied to the amplifiers until signal strength crosses a predetermined level, after which AGC bias is applied.

FM RECEIVER

RF section

- Consists of a pre-selector and an amplifier
- Pre-selector is a broad-tuned band pass filter with an adjustable center frequency used to reject unwanted radio frequency and to reduce the noise bandwidth.
- RF amplifier determines the sensitivity of the receiver and a predominant factor

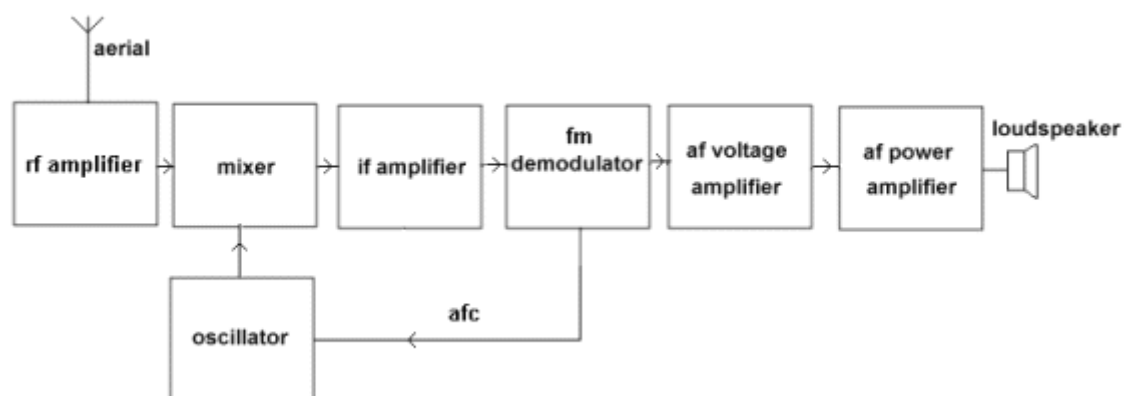

in determining the noise figure for the receiver.

Mixer/converter section

- Consists of a radio-frequency oscillator and a mixer.
- Choice of oscillator depends on the stability and accuracy desired.

- Mixer is a nonlinear device to convert radio frequency to intermediate frequencies (i.e. heterodyning process).

The shape of the envelope, the bandwidth and the original information contained in the envelope remains unchanged although the carrier and sideband frequencies are translated from RF to IF.

IF section

- Consists of a series of IF amplifiers and band pass filters to achieve most of the receiver gain and selectivity.
- The IF is always lower than the RF because it is easier and less expensive to construct high-gain, stable amplifiers for low frequency signals.
- IF amplifiers are also less likely to oscillate than their RF counterparts.

Detector section

- To convert the IF signals back to the original source information (demodulation).
- Can be as simple as a single diode or as complex as a PLL or balanced demodulator.

Audio amplifier section

- Comprises several cascaded audio amplifiers and one or more speakers

AGC (Automatic Gain Control)

- Adjust the IF amplifier gain according to signal level (to the average amplitude signal almost constant).
- AGC is a system by means of which the overall gain of radio receiver is varied automatically with the variations in the strength of received signals, to maintain the output constant.
- AGC circuit is used to adjust and stabilize the frequency of local oscillator.

Types of AGC –No AGC, Simple AGC, Delayed AGC.

Communication receiver

The receiving antenna intercepts the electromagnetic radiations and converts them into RF voltage. The RF signal is then applied to the RF amplifier through the antenna coupling, network, which matches the impedances of the antenna and the RE amplifier. The RF

amplifier amplifies this signal, which lies in the frequency range of 2 - 30 MHz. The amplified signal is fed to the first mixer, where it is mixed with the locally generated signal. The frequency of the local oscillator, f_{o1} is 650 kHz above the frequency of the receiver signal, f_s . Thus, the frequency range of the first local oscillator is $(f_s + 650 \text{ kHz})$. The first local oscillator and the RF amplifier are ganged together to generate the correct oscillator frequency.

The mixer circuit generates an IF signal whose frequency is 650 kHz. This IF signal is amplified by the first IF amplifier. After amplification, the IF signal is given to the second mixer, which mixes this signal with another locally generated signal generated by the second oscillator. The frequency of the second local oscillator is fixed at 500 kHz. As this frequency is fixed, a crystal oscillator is used in this stage to have good frequency stability. The second mixer generates the second IF signal. The value of the second IF frequency is 150 kHz, as it

is the difference between the first IF frequency (650 kHz) and the second local oscillator frequency (500 kHz). The frequency of

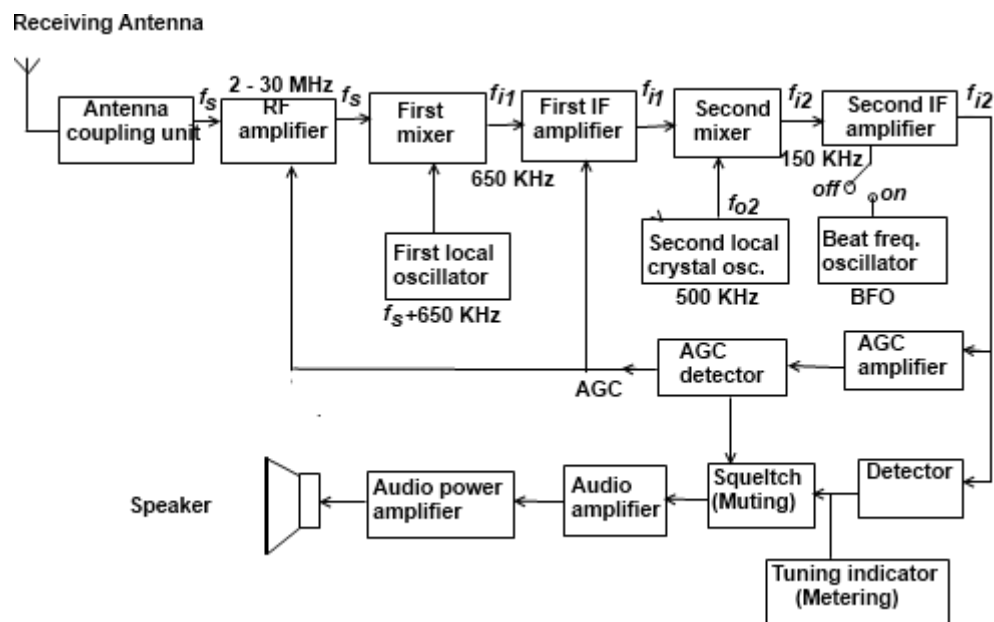

the second IF frequency is kept below the usual IF frequency of the AM receiver which is 455 kHz. The frequency of the first IF signal is kept above 455 kHz, up to a value of 650 kHz. With this arrangement, the communication receiver has the advantages of both low and high IF frequency. This technique of using two frequencies is known as double conversion. The second IF signal is now applied to the second IF amplifier, which amplifies it to the required value so that the signal is satisfactorily detected. The detector stage demodulates the received signal and gives its output as the modulating signal, which is an audio signal. This audio signal is then amplified by the audio stages which consist of the audio driver amplifier and the audio output power amplifier. The audio

signal is then given to the speaker, which produces the sound. To control the gains of the amplifiers of the system, AGC is employed. The AGC voltage is used to keep the volume of the receiver constant to the level set by the listener. The output of the second IF amplifier is also given to the AGC detector, as shown in Figure (a). The AGC detector produces a dc voltage, called the AGC bias voltage, which is proportion to the carrier strength of the received signal. The signal is also amplified by the AG amplifier before being detected to generate the AGC bias voltage. The AGC bias Voltage generated is applied to the RF amplifier and first IF amplifier, to control their gains. In addition to the above-mentioned sections of the AM communication receiver, communication receiver has additional features that described next. Beat Frequency Oscillator (BFO) Communication receivers can also receive telegraphic signals that use Morse code, which is a pulse modulated RF carrier signal. Morse code is transmitted as dots, dashes, and spaces. These are distinguished by different carrier frequencies with constant amplitude. A normal diode detector used in an AM system is not capable of distinguishing the presence or absence of a carrier signal, which is the usual technique to transmit Morse code. For example, the absence of a carrier signal may represent a space in the Morse code. To detect Morse code, a simple LC oscillator, which generates a constant frequency of 1 KHz or 400 Hz above or below the second IF frequency, is provided in the system. The LC oscillator is known as the BFO.. The output of the BFO is applied to the second IF amplifier as its second input. The second IF signal and the output of the BFO together generate whistles that indicate the presence of a dot, a dash, or a space. A switch is provided in the receiver to select the option of receiving an audio signal or a telegraph signal. This switch is in the off position when telegraph signals are not received. This provision is known as variable selectivity.

Squelch or Muting When the communication transmitter does not transmit any signal, the receiver receives only the noise present at its input. A good quality communication receiver can amplify this noise to produce a very loud noise from the speaker. The main reason behind this loud noise is that the AGC bias voltage which is proportion to the carrier strength is absent. In the absence of the RF signal. Thus, the gains of the RF and IF amplifiers are not controlled, and they provide maximum to the noise. The communication receivers used by police, ambulances, and coast guard radio stations are continuously operated. In these receivers, it is necessary to control the noise level in the absence of a carrier signal, as it will irritate the user. This is done by providing a Squelch or muting circuit in the system. The output of the AGC detector is also applied to the

squelch circuit, as shown in Figure (a). In the absence of a carrier, the AGC detector does not generate the AGC bias voltage. The squelch circuit, in this condition, cuts off the audio amplifier stages to block the noise signal to the speaker. As soon as the carrier signal is received, the AGC voltage is generated and the audio amplifiers work as normal. Metering (Tuning Indicator) Tuning indicator is provided in the receiver so that the operator knows if the receiver is tuned to the correct signal frequency. This process is also called metering of the strength of the received signal. The tuning indicator is either a set of light emitting diodes (LEDs) or an electronic meter, called an S-Meter. When the receiver is tuned to the correct signal frequency, both the side bands of the received signal are well accommodated and the detector generates a dc component. This dc component is proportional to the received carrier strength. The tuning indicator uses the dc component to indicate the strength of the received signal. The receiver is tuned until the tuning indicator indicates the maximum possible value for the desired tuned signal. Double Conversion in the double conversion technique, two intermediate frequencies are generated instead of then single intermediate frequency used in commercial AM receivers. In addition, this technique uses two local oscillators and two mixers, as shown in Figure (a). The first local oscillator is a variable frequency oscillator that can generate an IF frequency of 650 kHz. It is ganged with the RF amplifier to generate the correct local oscillator frequency so that the mixer gives an output 650 kHz.

Receiver RF Transmitter Level Transmitter Frequency Transmitter Amplifier Circuit Diagram

The second local oscillator is a crystal oscillator that generates a fixed frequency signal of 500 kHz. Therefore, the input to the second mixed is also a fixed IF frequency, and hence there is no need for a variable local oscillator frequency. The second mixer generates an IF signal at 150 kHz. The two basic reasons for double conversion are: • It provides advantages of having both higher and lower IF frequencies. • It provides a higher image frequency rejection. Due to these reasons, double conversion has become popular in communication receivers. Another technique called up-conversion, explained next, also though to get better selectivity of the receiver. Up-Conversion The conversion technique generates an IF with a frequency above the signal frequency. In conversion, IF frequency may have a value of 40 MHz for a signal frequency hand of 2-30 MHz The local oscillator frequency in this case will be $(f_s + 40 \text{ MHz})$. In AM receivers, IF frequency is kept lower

than the signal frequency: This lower signal is used because capacitors and inductors are available for selectivity networks, called filters, at lower frequencies. The invention of crystal and ceramic filters at very high frequencies provides an opportunity to adopt IF frequency higher than the signal frequencies. Thus, the up-conversion technique has become very popular in communication receivers due to the availability of good filters operated at higher frequencies.

CHAPTER-3

EM spectrum

The electromagnetic spectrum is the range of frequencies (the spectrum) of electromagnetic radiation and their respective wavelengths and photon energies.

The electromagnetic spectrum covers electromagnetic waves with frequencies ranging from below one hertz to above 1025 hertz, corresponding to wavelengths from thousands of kilometres down to a fraction of the size of an atomic nucleus. This frequency range is divided into separate bands, and the electromagnetic waves within each frequency band are called by different names; beginning at the low frequency (long wavelength) end of the spectrum these are: radio waves, microwaves, infrared, visible light, ultraviolet, X-rays, and gamma rays at the high-frequency (short wavelength) end. The electromagnetic waves in each of these bands have different characteristics, such as how they are produced, how they interact with matter, and their practical applications. The limit for long wavelengths is the size of the universe itself, while it is thought that the short wavelength limit is in the vicinity of the Planck length. Gamma rays, X-rays, and high ultraviolet are classified as ionizing radiation as their photons have enough energy to ionize atoms, causing chemical reactions. Exposure to these rays can be a health hazard, causing radiation sickness, DNA damage and cancer. Radiation of visible light wavelengths and lower are called nonionizing radiation as they cannot cause these effects.

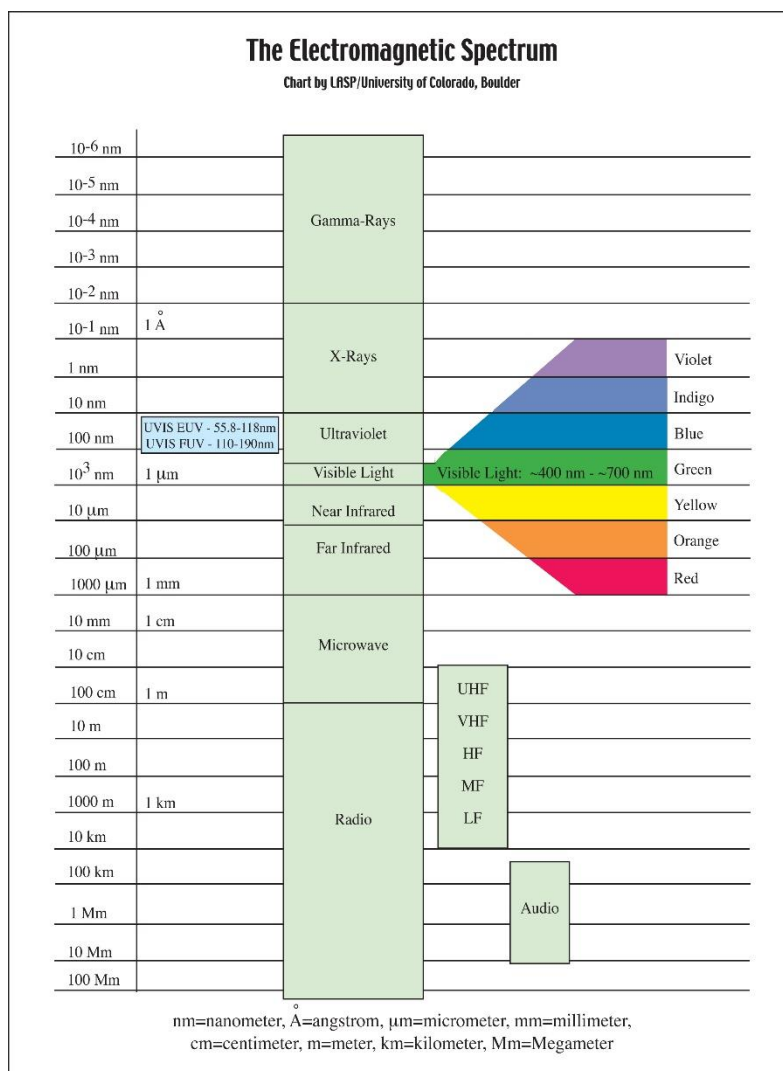

In most of the frequency bands above, a technique called spectroscopy can be used to physically separate waves of different frequencies, producing a spectrum showing the constituent frequencies. Spectroscopy is used to study the interactions of electromagnetic waves with matter. Other technological uses are described under electromagnetic radiation.

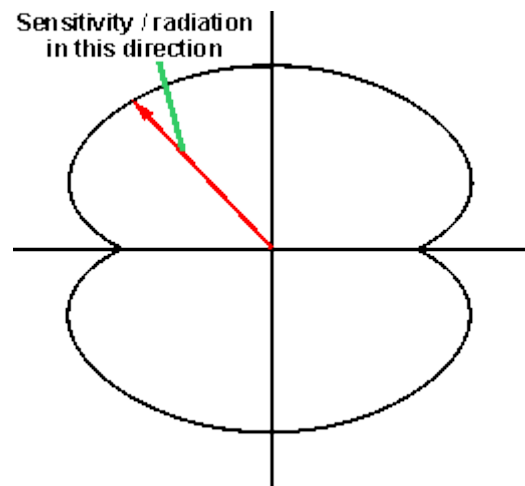

The radiation pattern of a dipole antenna is of particular importance.

The radiation pattern reflects the 'sensitivity' of the antenna in different directions and a knowledge of this allows the antenna to be orientated in the optimum direction to ensure the required performance.

Radiation pattern and polar diagram

The radiation pattern of any antenna can be plotted. This is plotted onto a polar diagram.

A polar diagram is a plot that indicates the magnitude of the response in any direction.

At the centre of the diagram is a point of referred to as the origin. This is surrounded by a curve whose radius at any given point is proportional to the magnitude of the property measured in the direction of that point.

Antenna polar diagram concept

Polar diagrams are used for plotting the radiation patterns of antennas as well as other applications like measuring the sensitivity of microphones in different directions, etc.

The radiation pattern shown on a polar diagram is taken to be that of the plane in which the diagram plot itself. For a dipole it is possible to look at both the along the axis of the antenna and also at right angles to it. Normally these would be either vertical or horizontal planes.

One fundamental fact about antenna radiation patterns and polar diagrams is that the receiving pattern, i.e. the receiving sensitivity as a function of direction is identical to the far-field radiation pattern of the antenna when used for transmitting. This results from the reciprocity theorem of electromagnetics. Accordingly, the radiation patterns the antenna can be viewed as either transmitting or receiving, whichever is more convenient.

Half wave dipole radiation pattern

The radiation pattern of a half wave dipole antenna that the direction of maximum sensitivity or radiation is at right angles to the axis of the RF antenna. The radiation falls to zero along the axis of the RF antenna as might be expected.

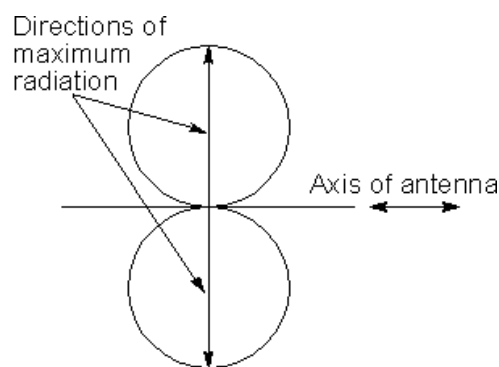

Radiation pattern of a half wave dipole antenna in free space

In a three dimensional plot, the radiation pattern envelope for points of equal radiation intensity for a doughnut type shape, with the axis of the antenna passing through the hole in the centre of the doughnut.

Radiation patterns for multiple half wavelength dipoles

If the length of the dipole antenna is changed from a half wavelength, then the radiation pattern is altered. As the length of the antenna is extended it can be seen that the familiar

figure of eight pattern changes to give main lobes and a few side lobes. The main lobes move progressively towards the axis of the antenna as the length increases.

Polarization of waves

Polarization, also called wave polarization, is an expression of the orientation of the lines of electric flux in an electromagnetic field (EM field). Polarization can be constant -- that is, existing in a particular orientation at all times, or it can rotate with each wave cycle.

Polarization is important in wireless communications systems. The physical orientation of a wireless antenna corresponds to the polarization of the radio waves received or transmitted by that antenna. Thus, a vertical antenna receives and emits vertically polarized waves, and a horizontal antenna receives or emits horizontally polarized waves. The best short-range communications are obtained when the transmitting and receiving (source and destination) antennas have the same polarization. The least efficient short-range communications usually take place when the two antennas are at right angles (for example, one horizontal and one vertical). Over long distances, the atmosphere can cause the polarization of a radio wave to fluctuate, so the distinction between horizontal and vertical becomes less significant.

Some wireless antennas transmit and receive EM waves whose polarization rotates 360 degrees with each complete wave cycle. This type of polarization, called elliptical or circular polarization, can be either clockwise or counter clockwise. The best communications results are obtained when the transmitting and receiving antennas have the same sense of polarization (both clockwise or both counter clockwise). The worst communications usually take place when the two antennas radiate and receive in the opposite sense (one clockwise and the other counter clockwise).

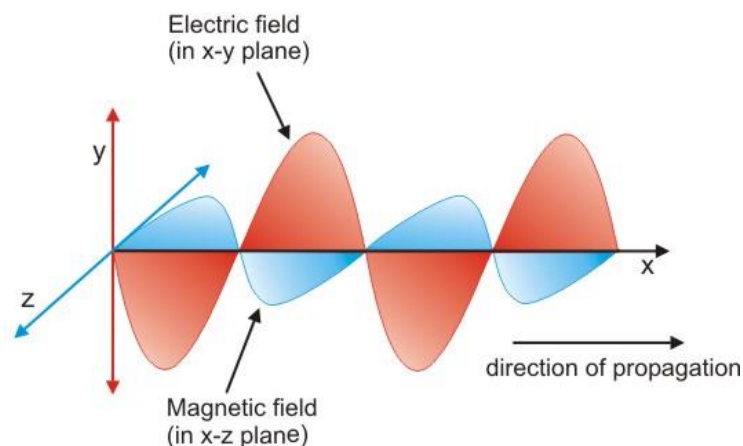

Polarization affects the propagation of EM fields at infrared (IR), visible, ultraviolet (UV), and even X-ray wavelengths. In ordinary visible light, there are numerous wave components at random polarization angles. When such light is passed through a special filter, the filter blocks all light except that having a certain polarization. When two polarizing filters are placed so a ray of light passes through them both, the amount of light transmitted depends on the angle of the polarizing filters with respect to each other. The most light is transmitted when the two filters are oriented so they polarize light in the same direction. The least light is transmitted when the filters are oriented at right angles to each other.

Point source

Radio wave sources which are smaller than one radio wavelength are also generally treated as point sources. Radio emissions generated by a fixed electrical circuit are usually polarized, producing anisotropic radiation. If the propagating medium is lossless, however, the radiant power in the radio waves at a given distance will still vary as the inverse square of the distance if the angle remains constant to the source polarization.

Directive gain or directivity

Is a different measure which does not take an antenna's electrical efficiency into account? This term is sometimes more relevant in the case of a receiving antenna where one is concerned mainly with the ability of an antenna to receive signals from one direction while rejecting interfering signals coming from a different direction.

Power gain

Power gain (or simply gain) is a unitless measure that combines an antenna's efficiency and directivity D .

$$G = \epsilon_{\text{antenna}} \cdot D$$

Aperture

In electromagnetics and antenna theory, antenna aperture, effective area, or receiving cross section, is a measure of how effective an antenna is at receiving the power of electromagnetic radiation (such as radio waves). The aperture is defined as the area, oriented perpendicular to the direction of an incoming electromagnetic wave, which would intercept the same amount of power from that wave as is produced by the antenna

receiving it. At any point, a beam of electromagnetic radiation has an irradiance or power flux density (PFD) which is the amount of energy passing through a unit area of one square meter

$$A_e = \frac{\lambda^2}{4\pi} G = \frac{c^2}{f^2} \times \frac{G}{4\pi}$$

Effective aperture

The effective antenna aperture/area is a theoretical value which is a measure of how effective an antenna is at receiving power. The effective aperture/area can be calculated by knowing the gain of the receiving antenna.

Where,

A_e = Effective Antenna Aperture

λ = Wavelength = C/f (where f = frequency, C = speed of light)

G = Antenna gain (Linear Value)

Radiation Pattern

The energy radiated by an antenna is represented by the Radiation pattern of the antenna. Radiation Patterns are diagrammatical representations of the distribution of radiated energy into space, as a function of direction.

The radiation patterns can be field patterns or power patterns.

The field patterns are plotted as a function of electric and magnetic fields. They are plotted on logarithmic scale.

The power patterns are plotted as a function of square of the magnitude of electric and magnetic fields. They are plotted on logarithmic or commonly on dB scale.

Beam width

In a radio antenna pattern, the half power beam width is the angle between the half-power (-3 dB) points of the main lobe, when referenced to the peak effective radiated power of the main lobe. See beam diameter. Beam width is usually but not always expressed in degrees and for the horizontal plane.

Radiation resistance is that part of an antenna's feed point resistance that is caused by the radiation of electromagnetic waves from the antenna, as opposed to loss resistance (also called ohmic resistance) which generally causes the antenna to heat up. The total of radiation resistance and loss resistance is the electrical resistance of the antenna.

Radiation resistance

The radiation resistance is determined by the geometry of the antenna, where loss resistance is primarily determined by the materials of which it is made. While the energy lost by ohmic resistance is converted to heat, the energy lost by radiation resistance is converted to electromagnetic radiation.

Radiation resistance is caused by the radiation reaction of the conduction electrons in the antenna.

Half wave dipole

The dipole antenna is cut and bent for effective radiation. The length of the total wire, which is being used as a dipole, equals half of the wavelength (i.e., $l = \lambda/2$). Such an antenna is called as **half-wave dipole antenna**. This is the most widely used antenna because of its advantages. It is also known as **Hertz antenna**.

Frequency range

The range of frequency in which half-wave dipole operates is around 3 KHz to 300GHz. This is mostly used in radio receivers.

Construction & Working of Half-Wave Dipole

It is a normal dipole antenna, where the frequency of its operation is **half of its wavelength**. Hence, it is called as half-wave dipole antenna.

The edge of the dipole has maximum voltage. This voltage is alternating (AC) in nature. At the positive peak of the voltage, the electrons tend to move in one direction and at the negative peak, the electrons move in the other direction. This can be explained by the

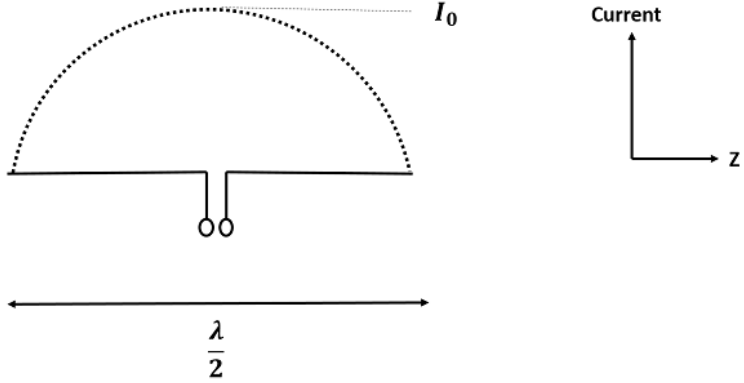

figures given below.

The figures given above show the working of a half-wave dipole.

- Fig 1 shows the dipole when the charges induced are in positive half cycle. Now the electrons tend to move towards the charge.
- Fig 2 shows the dipole with negative charges induced. The electrons here tend to

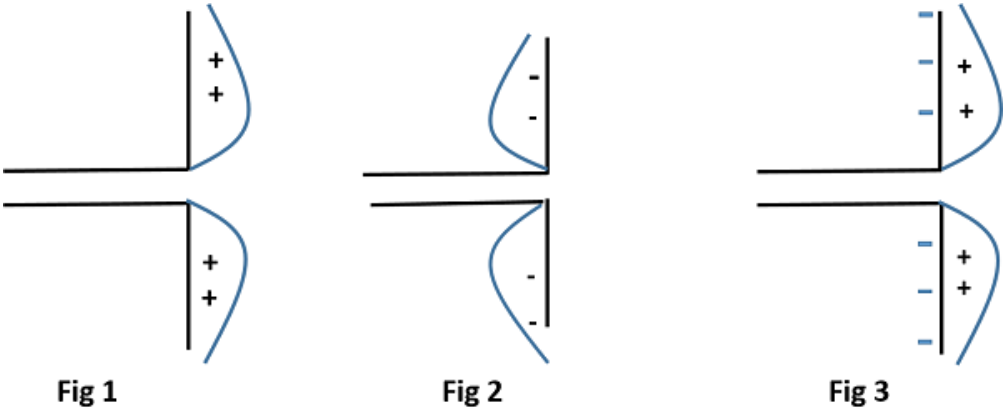

move away from the dipole.

- Fig 3 shows the dipole with next positive half cycle. Hence, the electrons again move towards the charge.

The cumulative effect of this produces a varying field effect which gets radiated in the same pattern produced on it. Hence, the output would be an effective radiation following the cycles of the output voltage pattern. Thus, a half-wave dipole **radiates effectively**.

The above figure shows the current distribution in half wave dipole. The directivity of half wave dipole is 2.15dBi, which is reasonably good. Where, 'I' represents the isotropic radiation.

Radiation Pattern

The radiation pattern of this half-wave dipole is **Omni-directional** in the H-plane. It is desirable for many applications such as mobile communications, radio receivers etc.

The above figure indicates the radiation pattern of a half wave dipole in both H-plane and V-plane.

The radius of the dipole does not affect its input impedance in this half wave dipole, because the length of this dipole is half wave and it is the first resonant length. An antenna works effectively at its **resonant frequency**, which occurs at its resonant length.

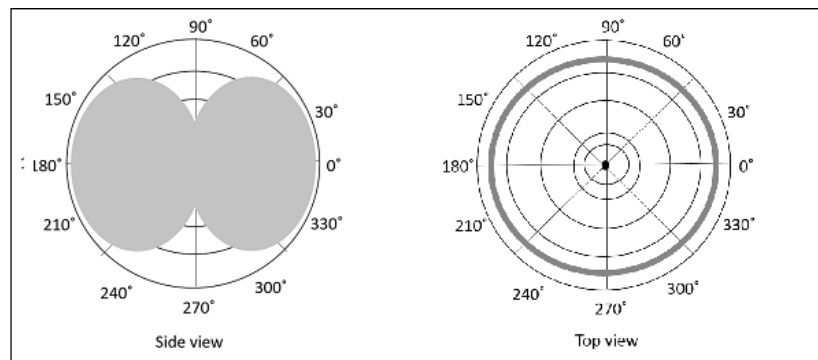

Advantages

The following are the advantages of half-wave dipole antenna –

- Input impedance is not sensitive.
- Matches well with transmission line impedance.
- Has reasonable length.
- Length of the antenna matches with size and directivity.

Disadvantages

The following are the disadvantages of half-wave dipole antenna –

- Not much effective due to single element.

- It can work better only with a combination.

Applications

The following are the applications of half-wave dipole antenna –

- Used in radio receivers.
- Used in television receivers.
- When employed with others, used for wide variety of applications.

Medium wave antenna

These antennas have been developed in order to cover mobile systems needs as well as the emergency service of temporary MW AM broadcasting. They can also be used as stationary antennas for services in the MW broadcasting range. The whole antenna system comprises: antenna, matching unit and a coaxial feeder line. The antenna consists of a grounded vertical tower with six folded wires spaced in 60 degrees around the tower. The folds are tied together on the ring at the base of the antenna. The matching unit is designed so that it can match transmitter output to the antenna input impedance over the whole MW band. All components are placed in a weatherproof Al-box that makes it ready for immediate service.

A flexible coaxial cable is used as a connection between the transmitter and the antenna matching unit, especially in case of mobile application. The ground screen consists of 60 copper wires equispaced around the tower. Each folded Unipolar Antenna is designed to withstand nominal radiating power +125 % amplitude modulation in the frequency range 525 to 1605 kHz.

A Folded Unipolar Antenna has the following advantages in comparison with series fed and top-loaded antennas:

- greater radiation resistance
- greater bandwidth of overall system
- no base insulator required, hence, the tower is at ground potential for lighting protection
- no lighting chokes or transformers are required when tower lights are used

- better stability in inclement weather

Folded dipole antenna

In its basic form the folded dipole antenna consists of a basic dipole with an added conductor connecting the two ends together to make a complete loop of wire or other conductor. As the ends appear to be folded back, the antenna is called a folded dipole.

The basic format for the folded dipole aerial is shown below. As can be seen from this it is a balanced antenna, like the standard dipole, although it can be fed with unbalanced feeder provided that a balun of some form is used to transform from an unbalanced to balance feed structure.

Half wave dipole antenna

The folded dipole antenna uses an extra wire connecting both ends of the previous dipole as shown. Often this is achieved by using a wire or rod of the same diameter for all sections of the antenna, but this is not always the case.

Also the wires or rods are typically equi-spaced along the length of the parallel elements. This can be achieved in a number of ways. Often for VHF or UHF antennas the rigidity of the elements is sufficient, but at lower frequencies spacers may need to be employed. To

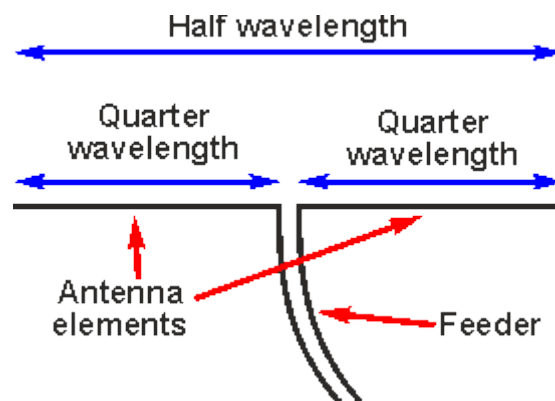

keep the wires apart. Obviously if they are not insulated it is imperative to keep them from shorting. In some instances, flat feeder can be used.

Half-wave folded dipole antenna

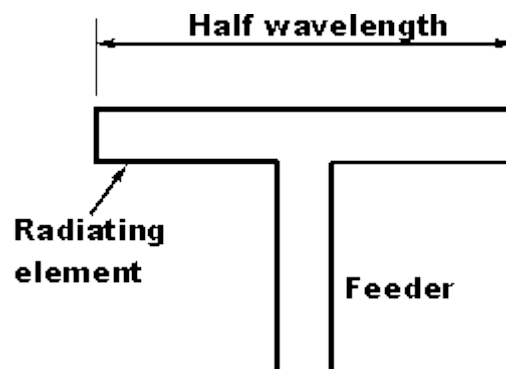

One of the main reasons for using the folded dipole aerial is the increase in feed impedance that it provides. If the conductors in the main dipole and the second or "fold" conductor are the same diameter, then it is found that there is a fourfold increase (i.e. two squared) in the feed impedance. In free space, this gives an increase in feed impedance from 73Ω to around 300Ω ohms. Additionally, the RF antenna has a wider bandwidth.

Loop antenna

A loop antenna is a radio antenna consisting of a loop or coil of wire, tubing, or other electrical conductor usually fed by a balanced source or feeding a balanced load. Within this physical description there are two distinct antenna types. The large self-resonant loop antenna has a circumference close to one wavelength of the operating frequency and so is resonant at that frequency. This category also includes smaller loops 5% to 30% of a wavelength in circumference, which use a capacitor to make them resonant. These antennas are used for both transmission and reception. In contrast, small loop antennas less than 1% of a wavelength in size are very inefficient radiators, and so are only used for reception. An example is the ferrite (loop stick) antenna used in most AM broadcast radios. Loop antennas have a dipole radiation pattern; they are most sensitive to radio

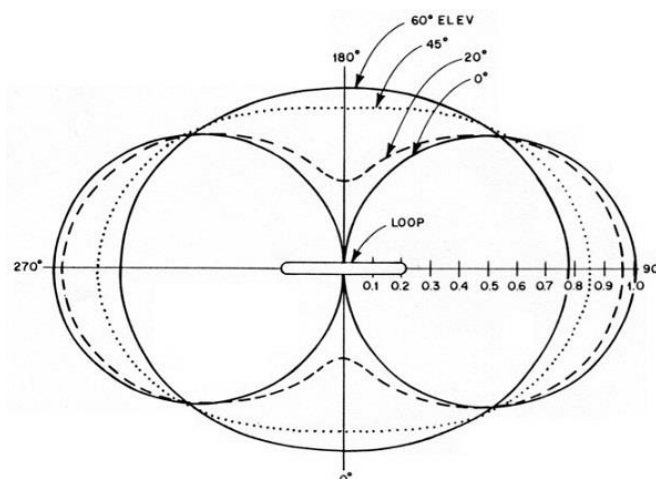

waves in two broad lobes in opposite directions, 180° apart. Due to this directional pattern they are used for radio direction finding (RDF), to locate the position of a transmitter.

Radiation Pattern

The radiation pattern of these antennas will be same as that of short horizontal dipole antenna.

The radiation pattern for small, high-efficiency loop antennas is shown in the figure given above. The radiation patterns for different angles of looping are also illustrated clearly in the figure. The tangent line at 0° indicates vertical polarization, whereas the line with 90° indicates horizontal polarization.

Advantages

The following are the advantages of Loop antenna –

- Compact in size
- High directivity

Disadvantages

- The following are the disadvantages of Loop antenna –
- Impedance matching may not be always good
- Has very high resonance quality factor

Applications

- The following are the applications of Loop antenna –
- Used in RFID devices
- Used in MF, HF and Short wave receivers
- Used in Aircraft receivers for direction finding
- Used in UHF transmitters

Yagi Antenna / Yagi-Uda Antenna

The Yagi antenna or Yagi-Uda antenna / aerial is one of the most successful RF antenna designs for directive antenna applications. The Yagi or Yagi-Uda antenna is used in a wide variety of applications where an RF antenna design with gain and directivity is required. The Yagi has become particularly popular for television reception, but it is also used in very many other domestic and commercial applications where an RF antenna is needed that has gain and directivity. Not only is the gain of the Yagi antenna important as it enables better levels of signal to noise ratio to be achieved, but also the directivity can be

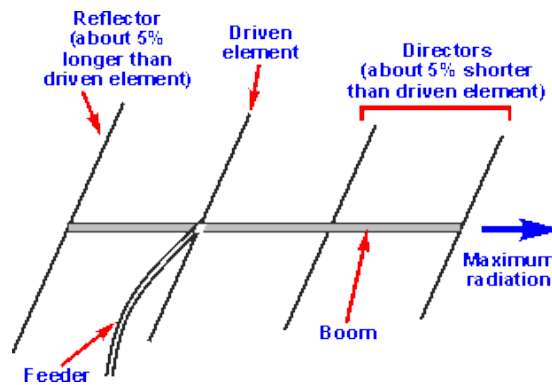

used to reduce interference levels by focussing the transmitted power on areas where it is needed, or receiving signals best from where the emanate.

Yagi antenna - the basics

The Yagi antenna design has a dipole as the main radiating or driven element. Further 'parasitic' elements are added which are not directly connected to the driven element.

These parasitic elements within the Yagi antenna pick up power from the dipole and re-radiate it. The phase is in such a manner that it affects the properties of the RF antenna as a whole, causing power to be focussed in one particular direction and removed from others.

The parasitic elements of the Yagi antenna operate by re-radiating their signals in a slightly different phase to that of the driven element. In this way the signal is reinforced in some directions and cancelled out in others. It is found that the amplitude and phase of the current that is induced in the parasitic elements is dependent upon their length and the spacing between them and the dipole or driven element.

There are three types of element within a Yagi antenna:

- Driven element: The driven element is the Yagi antenna element to which power is applied. It is normally a half wave dipole or often a folded dipole.
- Reflector: The Yagi antenna will generally only have one reflector. This is behind the main driven element, i.e. the side away from the direction of maximum sensitivity.

Further reflectors behind the first one adds little to the performance. However, many designs use reflectors consisting of a reflecting plate, or a series of parallel rods simulating a reflecting plate. This gives a slight improvement in performance, reducing the level of radiation or pick-up from behind the antenna, i.e. in the backwards direction. Typically, a reflector will add around 4 or 5 dB of gain in the forward direction.

- Director: There may be none, one or more reflectors in the Yagi antenna. The director or directors are placed in front of the driven element, i.e. in the direction of maximum sensitivity. Typically, each director will add around 1 dB of gain in the forward direction, although this level reduces as the number of director's increases.

The antenna exhibits a directional pattern consisting of a main forward lobe and a number of spurious side lobes. The main one of these is the reverse lobe caused by radiation in the direction of the reflector. The antenna can be optimised to either reduce this or produce the maximum level of forward gain. Unfortunately, the two do not coincide exactly and a compromise on the performance has to be made depending upon the application.

Yagi antenna advantages

- The Yagi antenna offers many advantages for its use. The antenna provides many advantages in a number of applications:
- Antenna has gain allowing lower strength signals to be received.
- Yagi antenna has directivity enabling interference levels to be minimised.
- Straightforward construction. - The Yagi antenna allows all constructional elements to be made from rods simplifying construction.

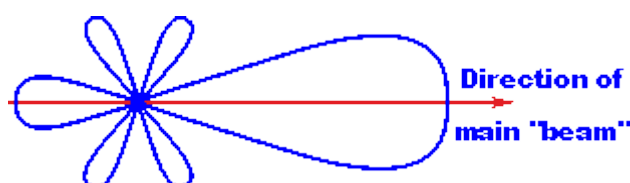

- The construction enables the antenna to be mounted easily on vertical and other poles with standard mechanical fixings

The Yagi antenna also has a number of disadvantages that need to be considered.

- For high gain levels the antenna becomes very long
- Gain limited to around 20dB or so for a single antenna

The Yagi antenna is a particularly useful form of RF antenna design. It is widely used in applications where an RF antenna design is required to provide gain and directivity. In this way the optimum transmission and reception conditions can be obtained.

Ferrite rod antenna

The ferrite rod antenna is a form of RF antenna design that is almost universally used in portable transistor broadcast receivers as well as many hi-fi tuners where reception on the long, medium and possibly the short wave bands is required.

Ferrite rod antennas are also being used increasingly in wireless applications in areas such as RFID. Here the volumes of antennas required can be huge. The antennas also need

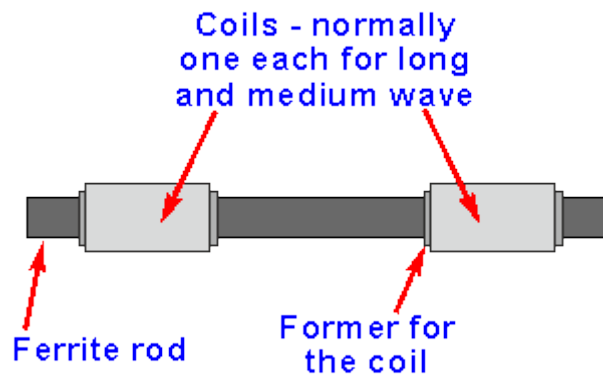

to be compact and effective, making ferrite rod antennas an ideal solution.

Ferrite rod antenna basics

As the name suggests the antenna consists of a rod made of ferrite, an iron based magnetic material. A coil is wound around the ferrite rod and this is brought to resonance using a variable tuning capacitor contained within the radio circuitry itself and in this way the antenna can be tuned to resonance. As the antenna is tuned it usually forms the RF tuning circuit for the receiver, enabling both functions to be combined within the same components, thereby reducing the number of components and hence the cost of the set.

Typical ferrite rod antenna assembly used in a portable radio

The ferrite rod antenna operates using the high permeability of the ferrite material and in its basic form this may be thought of as "concentrating" the magnetic component of the radio waves. This is brought about by the high permeability μ of the ferrite.

The fact that this RF antenna uses the magnetic component of the radio signals in this way means that the antenna is directive. It operates best only when the magnetic lines of force fall in line with the antenna. This occurs when it is at right angles to the direction of the transmitter. This means that the antenna has a null position where the signal level is at a minimum when the antenna is in line with the direction of the transmitter.

Operation of a ferrite rod antenna

Ferrite rod antenna performance

This form of RF antenna design is very convenient for portable applications, but its efficiency is much less than that of a larger RF antenna. The performance of the ferrite also limits the frequency response. Normally this type of RF antenna design is only

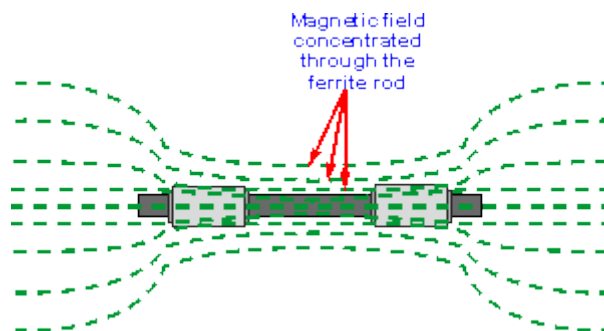

effective on the long and medium wave bands, but it is sometimes used for lower frequencies in the short wave bands although the performance is significantly degraded, mainly arising from the losses in the ferrite. This limits their operation normally to frequencies up to 2 or 3 MHz

Ferrite rod antennas are normally only used for receiving. They are rarely used for transmitting anything above low levels of power in view of their poor efficiency. If any reasonable levels of power were fed into them they would soon become very hot and there would be a high likelihood that they would be destroyed. Nevertheless, they can be used as a very compact form of transmitting antenna for applications where efficiency is not an issue and where power levels are very low. As they are very much more compact

than other forms of low or medium frequency RF antenna, this can be an advantage, and as a result they are being used in applications such as RFID.

Broadside Array

The broadside array is defined as “the radiation pattern's direction is perpendicular or broadside to the array axis”.

It uses the dipole elements that are fed in phase and separated by the one-half wave length. A broadside array is a type of antenna array which is used to radiate the energy in specific direction to make better transmission. It is a bidirectional array which can send and receive process at both ends (sending and receiving end).

The front view of the broadside array is shown below.

The side view of the broadside array is shown below.

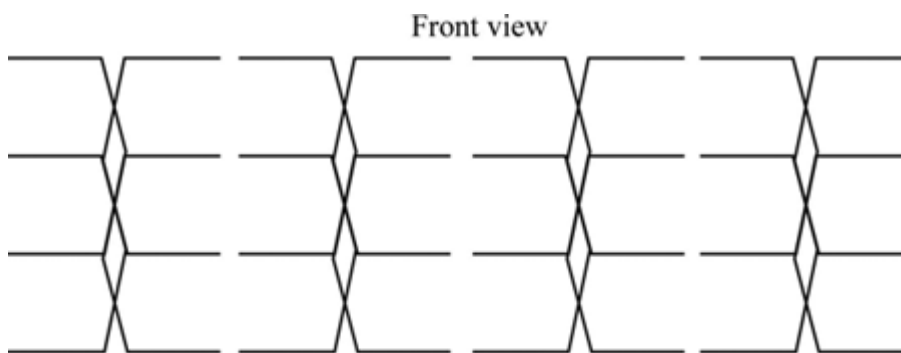

Figure 1

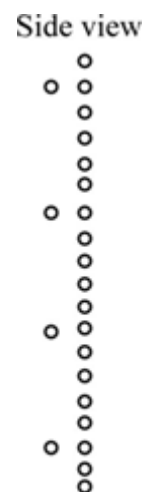
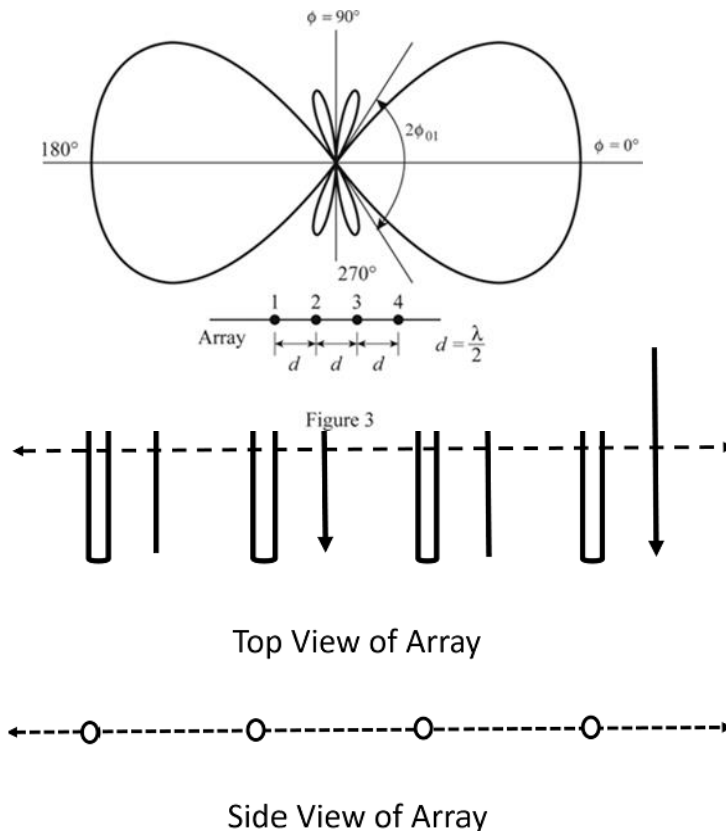

Figure 2

From this Figure 1, the broadside array is at extreme right angle direction to the array plane. However, due to pattern cancellation in the path joining at the centre, the radiation pattern is too less.

Radiation pattern:



There are different types antenna array present. Each have their own radiation pattern. The broadside array's pattern is drawn.

This pattern is at right angles to the plane and is bi-directional. The radiation beam has very narrow pattern and has high gain.

End fire array

The physical arrangement of **end-fire array** is same as that of the broad side array. The magnitude of currents in each element is same, but there is a phase difference between these currents. This induction of energy differs in each element, which can be understood by the following diagram.

The above figure shows the end-fire array in top and side views respectively.

There is no radiation in the right angles to the plane of the array because of cancellation. The first and third elements are fed out of phase and therefore cancel each other's radiation. Similarly, second and fourth are fed out of phase, to get cancelled.

The usual dipole spacing will be $\lambda/4$ or $3\lambda/4$. This arrangement not only helps to avoid the radiation perpendicular to the antenna plane, but also helps the radiated energy get diverted to the direction of radiation of the whole array. Hence, the minor lobes are

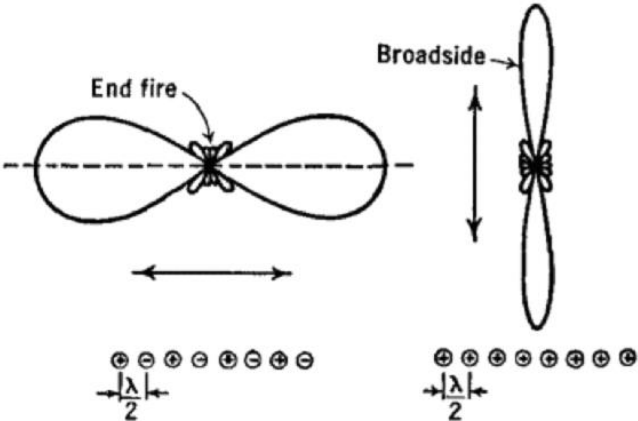

avoided and the directivity is increased. The beam becomes narrower with the increased elements.

Radiation Pattern

The Radiation pattern of end-fire array is **uni-directional**. A major lobe occurs at one end, where maximum radiation is present, while the minor lobes represent the losses.

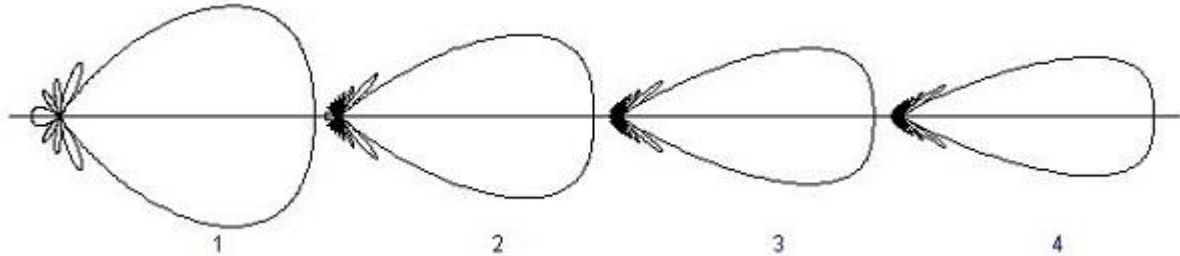

The figure explains the radiation pattern of an end-fire array. Figure 1 is the radiation pattern for a single array, while figures 2, 3, and 4 represent the radiation pattern for multiple arrays.

End-fire Array Vs Broad Side Array

We have studied both the arrays. Let us try to compare the end-fire and broad side arrays, along with their characteristics.

The figure illustrates the radiation pattern of end-fire array and broad side array.

- Both, the end fire array and broad side array, are linear and are resonant, as they consist of resonant elements.

- Due to resonance, both the arrays display narrower beam and high directivity.
- Both of these arrays are used in transmission purposes.
- Neither of them is used for reception, because the necessity of covering a range of frequencies is needed for any kind of reception.

Rhombic antenna

The **Rhombic Antenna** is an equilateral parallelogram shaped antenna. Generally, it has two opposite acute angles. The tilt angle, θ is approximately equal to 90° minus the angle of major lobe. Rhombic antenna works under the principle of travelling wave radiator. It is arranged in the form of a rhombus or diamond shape and suspended horizontally above the surface of the earth.

Frequency Range

The frequency range of operation of a rhombic antenna is around **3MHz to 300MHz**. This antenna works in **HF** and **VHF** ranges.

Construction of Rhombic Antenna

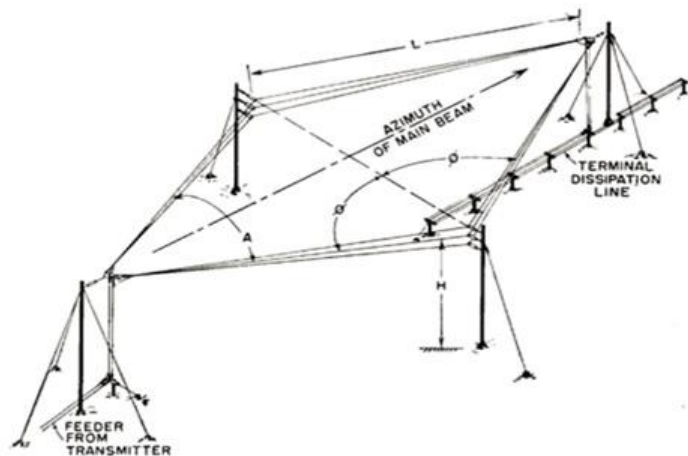

Rhombic antenna can be regarded as two V-shaped antennas connected end-to-end to form obtuse angles. Due to its simplicity and ease of construction, it has many uses –

- In HF transmission and reception
- Commercial point-to-point communication

The construction of the rhombic antenna is in the form a rhombus, as shown in the figure.

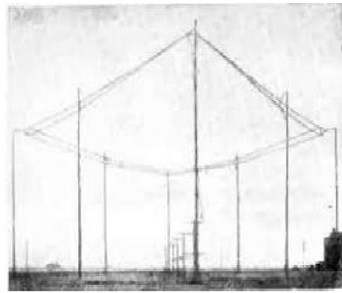

Figure 1

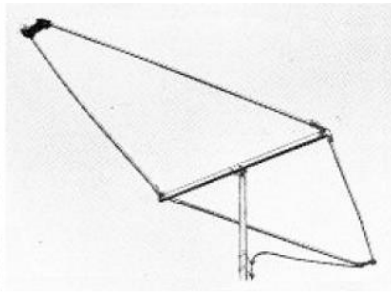

Figure 2

The two sides of rhombus are considered as the conductors of a two-wire transmission line. When this system is properly designed, there is a concentration of radiation along the main axis of radiation. In practice, half of the power is dissipated in the terminating resistance of the antenna. The rest of the power is radiated. The wasted power contributes to the minor lobes.

Figure 1 shows the construction of **rhombic antenna** for point-to-point communication in olden days. Figure 2 shows the **rhombic UHF antenna** for TV reception, used these days.

The maximum gain from a rhombic antenna is along the direction of the main axis, which passes through the feed point to terminate in free space. The polarization obtained from a horizontal rhombic antenna is in the plane of rhombus, which is horizontal.

Radiation Pattern

The radiation pattern of the rhombic antenna is shown in the following figure. The resultant pattern is the cumulative effect of the radiation at all four legs of the antenna. This pattern is **uni-directional**, while it can be made bi-directional by removing the terminating resistance.

The main disadvantage of rhombic antenna is that the portions of the radiation, which do not combine with the main lobe, result in considerable side lobes having both horizontal and vertical polarization.

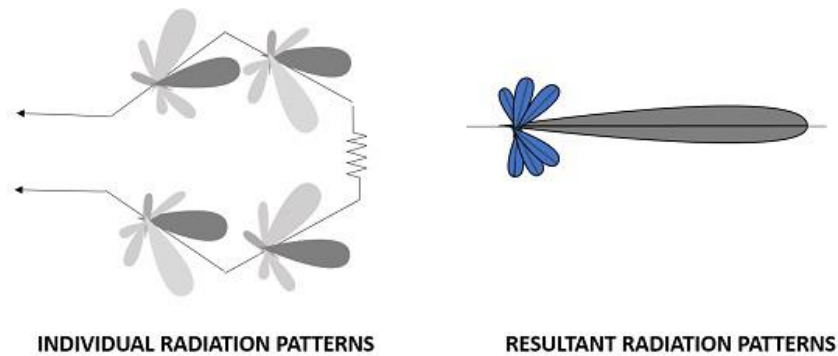

Advantages

The following are the advantages of rhombic antenna –

- Input impedance and radiation pattern are relatively constant
- Multiple rhombic antennas can be connected
- Simple and effective transmission

Disadvantages

The following are the disadvantages of rhombic antenna –

- Wastage of power in terminating resistor
- Requirement of large space
- Reduced transmission efficiency

Applications

The following are the applications of rhombic antenna –

- Used in HF communications
- Used in Long distance sky wave propagations
- Used in point-to-point communications

Another method of using long wire is by bending and making the wire into a loop shaped pattern and observing its radiational parameters. This type of antennas is termed as **loop antennas**.

Parabolic antenna

A parabolic antenna is an antenna that uses a parabolic reflector, a curved surface with the cross-sectional shape of a parabola, to direct the radio waves. The most common form is shaped like a dish and is popularly called a dish antenna or parabolic dish. The main advantage of a parabolic antenna is that it has high directivity. It functions similarly to a searchlight or flashlight reflector to direct the radio waves in a narrow beam, or receive radio waves from one particular direction only. Parabolic antennas have some of the highest gains, meaning that they can produce the narrowest beam widths, of any antenna type. In order to achieve narrow beam widths, the parabolic reflector must be much larger than the wavelength of the radio waves used, so parabolic antennas are used in the high frequency part of the radio spectrum, at UHF and microwave (SHF) frequencies, at which the wavelengths are small enough that conveniently-sized reflectors can be used.

Parabolic antennas are used as high-gain antennas for point-to-point communications, in applications such as microwave relay links that carry telephone and television signals between nearby cities, wireless WAN/LAN links for data communications, satellite communications and spacecraft communication antennas. They are also used in radio telescopes.

The other large use of parabolic antennas is for radar antennas, in which there is a need to transmit a narrow beam of radio waves to locate objects like ships, airplanes, and guided missiles, and often for weather detection. With the advent of home satellite television receivers, parabolic antennas have become a common feature of the landscapes of modern countries.

The parabolic antenna was invented by German physicist Heinrich Hertz during his discovery of radio waves in 1887. He used cylindrical parabolic reflectors with spark-excited dipole antennas at their focus for both transmitting and receiving during his historic experiments.

CHAPTER-4

Surface Waves

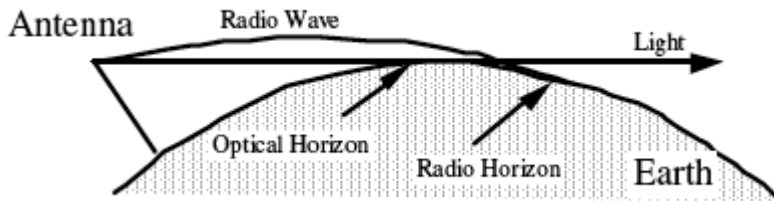

These are the principle waves used in AM, FM and TV broadcast. Objects such as buildings, hills, ground conductivity, etc. have a significant impact on their strength. Surface waves are usually vertically polarized with the electric field lines in contact with the earth.

$$d_{\max} \approx \sqrt{17h_t} + \sqrt{17h_r} \text{ km}$$

Refraction

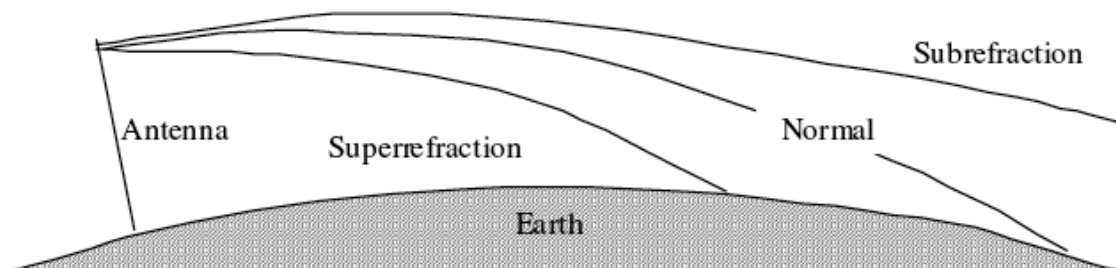

Because of refraction, the radio horizon is larger than the optical horizon by about 4/3. The typical maximum direct wave transmission distance (in km) is dependent on the height of the transmitting and receiving antennas (in meters):

However, the atmospheric conditions can have a dramatic effect on the amount of refraction.

Super Refraction

In super refraction, the rays bend more than normal thus shortening the radio horizon. This phenomenon occurs when temperature increases but moisture decreases with

height. Paradoxically, in some cases, the radio wave can travel over enormous distances. It can be reflected by the earth, rebroadcast and super refracted again.

Sub refraction

In sub refraction, the rays bend less than normal. This phenomenon occurs when temperature decreases but moisture increases with height. In extreme cases, the radio signal may be refracted out into space.

Space Waves

These waves occur within the lower 20 km of the atmosphere, and are comprised of a direct and reflected wave. The radio waves having high frequencies are basically called as space waves. These waves have the ability to propagate through atmosphere, from transmitter antenna to receiver antenna. These waves can travel directly or can travel after reflecting from earth's surface to the troposphere surface of earth. So, it is also called

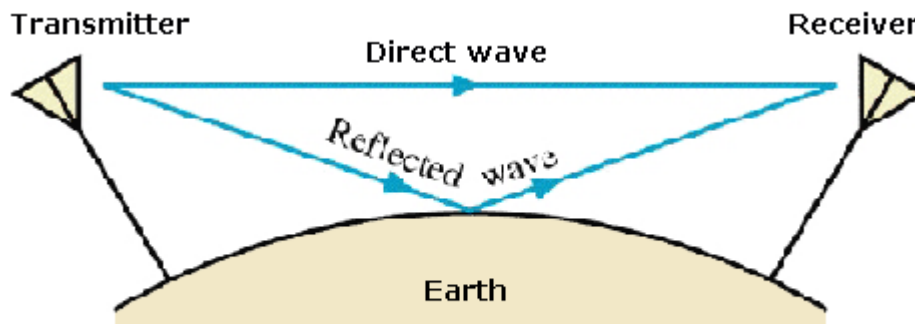

Space wave, comprising direct + reflected waves

as Tropospheric Propagation. In the diagram of medium wave propagation, c shows the space wave propagation. Basically the technique of space wave propagation is used in bands having very high frequencies. E.g. V.H.F. band, U.H.F band etc. At such higher frequencies the other wave propagation techniques like sky wave propagation, ground wave propagation can't work. Only space wave propagation is left which can handle frequency waves of higher frequencies. The other name of space wave propagation is line of sight propagation. There are some limitations of space wave propagation.

1. These waves are limited to the curvature of the earth.
2. These waves have line of sight propagation, means their propagation is along the line of sight distance.

The line of sight distance is that exact distance at which both the sender and receiver antenna are in sight of each other. So, from the above line it is clear that if we want to increase the transmission distance then this can be done by simply extending the heights of both the sender as well as the receiver antenna. This type of propagation is used basically in radar and television communication.

The frequency range for television signals is nearly 80 to 200 MHz these waves are not reflected by the ionosphere of the earth. The property of following the earth's curvature is also missing in these waves. So, for the propagation of television signal, geostationary satellites are used. The satellites complete the task of reflecting television signals towards earth. If we need greater transmission, then we have to build extremely tall antennas.

Direct Wave

This is generally a line of sight transmission, however, because of atmospheric refraction the range extends slightly beyond the horizon.

Ground Reflected Wave

Radio waves may strike the earth, and bounce off. The strength of the reflection depends on local conditions. The received radio signal can cancel out if the direct and reflected waves arrive with the same relative strength and 180° out of phase with each other.

Horizontally polarized waves are reflected with almost the same intensity but with an 180° phase reversal.

Vertically polarized waves generally reflect less than half of the incident energy. If the angle of incidence is greater than 10° there is very little change in phase angle.

Sky Waves

These waves head out to space but are reflected or refracted back by the ionosphere. The height of the ionosphere ranges from 50 to 1,000 km. Radio waves are refracted by the ionized gas created by solar radiation. The amount of ionization depends on the time of day, season and the position in the 11-year sun spot cycle. The specific radio frequency refracted is a function of electron density and launch angle. A communication channel thousands of kilometres long can be established by successive reflections at the earth's surface and in the upper atmosphere. This ionosphere propagation takes place mainly in

the HF band. The ionosphere is composed of several layers, which vary according to the time of day. Each layer has different propagation characteristics:

- D layer – This layer occurs only during the day at altitudes of 60 to 90 km. High absorption takes place at frequencies up to 7 MHz
- E layer – This layer occurs at altitudes of 100 to 125 km. In the summer, dense ionization clouds can form for short periods. These clouds called *sporadic E* can refract radio signals in the VHF spectrum. This phenomenon allows amateur radio operators to communicate over enormous distances.
- F layer - This single night-time layer splits into two layers (F1 and F2) during the day. The F1 layer forms at about 200 km and F2 at about 400 km. The F2 layer propagates most HF short-wave transmissions.

Because radio signals can take many paths to the receiver, multipath fading can occur. If the signals arrive in phase, the result is a stronger signal. If they arrive out of phase with each other, they tend to cancel. Deep fading, lasting from minutes to hours over a wide frequency range, can occur when solar flares increase the ionization in the D layer. The useful transmission band ranges between the LUF (lowest usable frequency) and MUF (maximum usable frequency). Frequencies above the MUF are refracted into space. Below the LUF, radio frequencies suffer severe absorption. If a signal is near either of these two extremes, it may be subject to fading. Meteors create ionization trails that reflect radio waves. Although these trails exist for only a few seconds, they have been successfully used in communications systems spanning 1500 km. The Aurora Borealis or Northern Lights cause random reflection in the 3 - 5 MHz region. Aurora causes signal flutter at 100 Hz to 2000 Hz thus making voice transmission impossible.

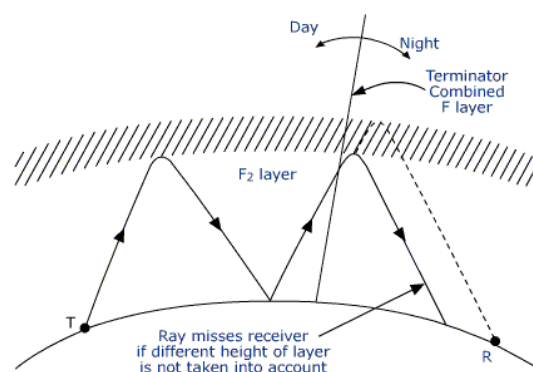

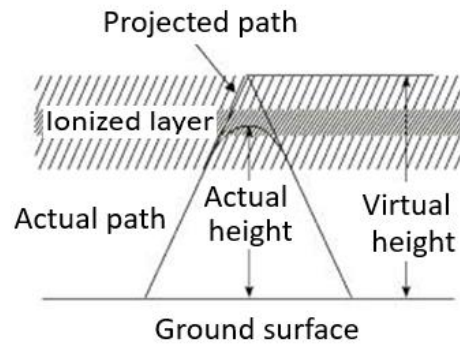

Ionosphere

The ionosphere is the ionized part of Earth's upper atmosphere, from about 60 km (37 mi) to 1,000 km (620 mi) altitude, a region that includes the thermosphere and parts of the mesosphere and exosphere. The ionosphere is ionized by solar radiation. It plays an important role in atmospheric electricity and forms the inner edge of the magnetosphere. It has practical importance because, among other functions, it influences radio propagation to distant places on the Earth.

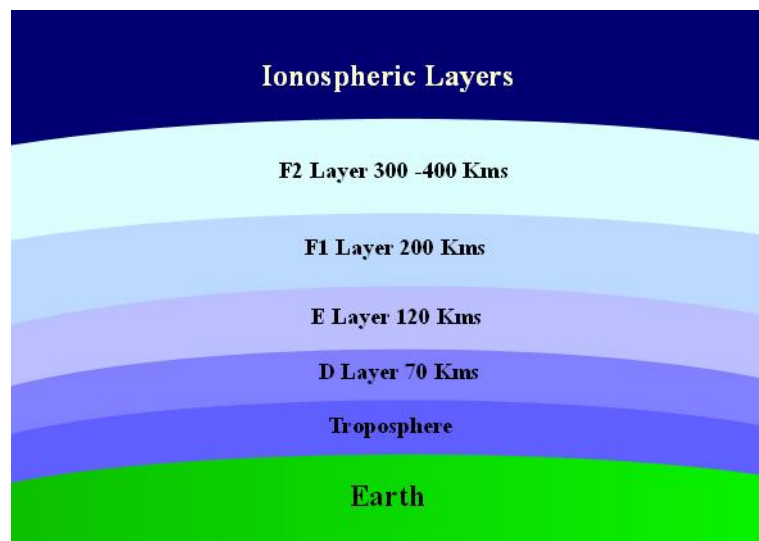

In the process of propagation of a wave, there are few terms which we come across quite often. Let us discuss about these terms one by one.

Virtual Height

When a wave is refracted, it is bent down gradually, but not sharply. However, the path of incident wave and reflected wave are same if it is reflected from a surface located at a greater height of this layer. Such a greater height is termed as virtual height.

The figure clearly distinguishes the virtual height (height of wave, supposed to be reflected) and actual height (the refracted height). If the virtual height is known, the angle of incidence can be found.

Critical Frequency

Critical frequency for a layer determines the highest frequency that will be returned down to the earth by that layer, after having been beamed by the transmitter, straight up into the sky.

The rate of ionization density, when changed conveniently through the layers, the wave will be bent downwards. The maximum frequency that gets bent and reaches the receiver station with minimum attenuation, can be termed as critical frequency. This is denoted by f_c .

Multi-path

For the frequencies above 30 MHz, the sky wave propagation exists. Signal multipath is the common problem for the propagation of electromagnetic waves going through Sky wave. The wave, which is reflected from the ionosphere, can be called as a hop or skip. There can be a number of hops for the signal as it may move back and forth from the ionosphere and earth surface many times. Such a movement of signal can be termed as multipath.

The above figure shows an example of multi-path propagation. Multipath propagation is a term, which describes the multiple paths a signal travels to reach the destination. These paths include a number of hops. The paths may be the results of reflection,

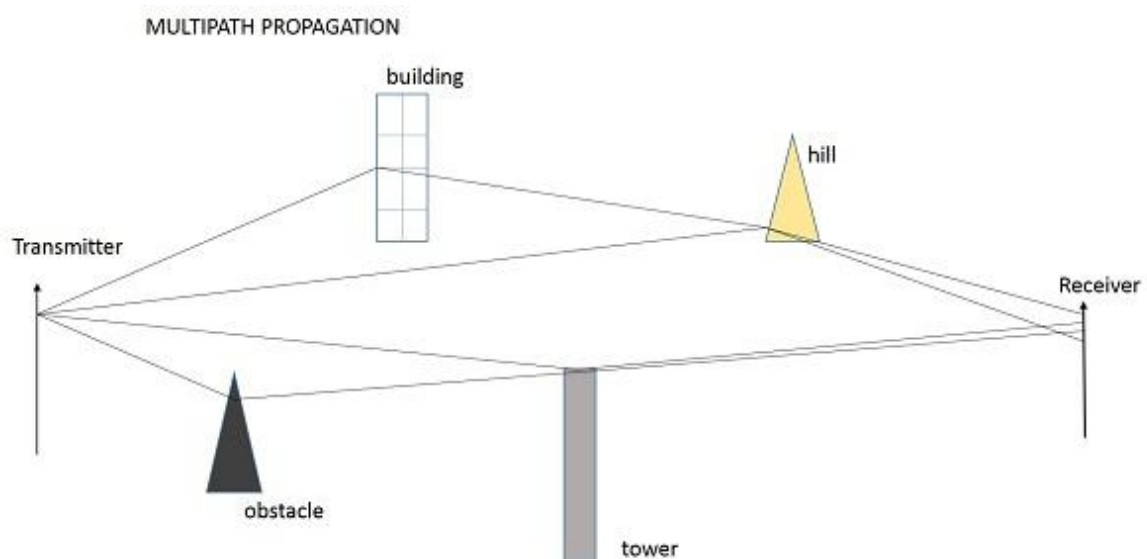

refraction or even diffraction. Finally, when the signal from such different paths gets to the receiver, it carries propagation delay, additional noise, and phase differences etc., which decrease the quality of the received output.

Fading

The decrease in the quality of the signal can be termed as fading. This happens because of atmospheric effects or reflections due to multipath.

Fading refers to the variation of the signal strength with respect to time/distance. It is widely prevalent in wireless transmissions. The most common causes of fading in the wireless environment are multipath propagation and mobility (of objects as well as the communicating devices).

Skip Distance

The measurable distance on the surface of the Earth from transmitter to receiver, where the signal reflected from the ionosphere can reach the receiver with minimum hops or skips, is known as skip distance.

Maximum Usable Frequency (MUF)

The Maximum Usable Frequency (MUF) is the highest frequency delivered by the transmitter regardless of the power of the transmitter. The highest frequency, which is reflected from the ionosphere to the receiver is called as critical frequency, f_c .

Optimum Working Frequency (OWF)

The frequency, which is being used mostly for a particular transmission and which has been predicted to be used over a particular period of time, over a path, is termed as Optimum Working Frequency (OWF).

Inter Symbol Interference

Inter symbol interference (ISI) occurs more commonly in communication system. This is the main reason for signal multipath also. When signals arrive at the receiving stations via different propagation paths, they cancel out each other, which is known as the phenomenon of signal fading. Here, it should be remembered that the signals cancel out themselves in vector way.

Skin Depth

Electromagnetic waves are not suitable for underwater propagations. However, they can propagate under water provided we make the frequency of propagation extremely low. The attenuation of electromagnetic waves under water is expressed in terms of skin

depth. Skin depth is defined as the distance at which the signal is attenuated by $1/e$. It is a measure of depth to which an EM wave can penetrate. Skin depth is represented as δ (delta).

Duct Propagation

At a height of around 50 mts from the troposphere, a phenomenon exists; the temperature increases with the height. In this region of troposphere, the higher frequencies or microwave frequencies tend to refract back into the Earth's atmosphere, instead of shooting into ionosphere, to reflect. These waves propagate around the curvature of the earth even up to a distance of 1000km.

This refraction goes on continuing in this region of troposphere. This can be termed as

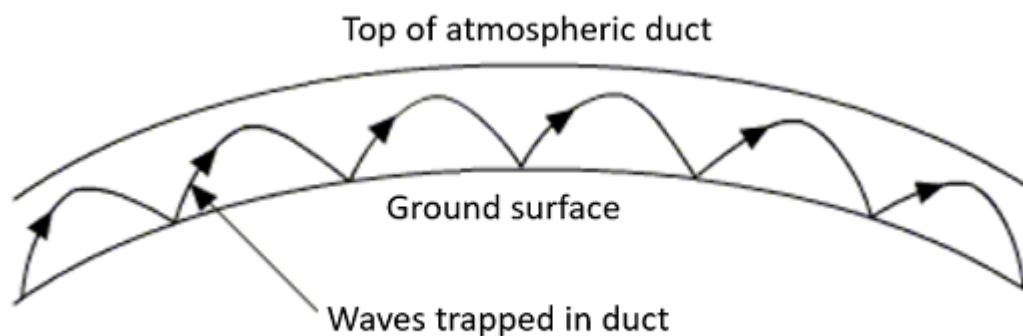

Super refraction or Duct propagation.

The above image shows the process of Duct Propagation. The main requirement for the duct formation is the temperature inversion. The increase of temperature with height, rather than the decrease in the temperature is known as the phenomenon of temperature inversion.

We have discussed the important parameters, which we come across in wave propagation. The waves of higher frequencies are transmitted and received using this wave propagation technique.

CHAPTER-5

Pulse code modulation

Pulse-code modulation (PCM) is a method used to digitally represent sampled analog signals. It is the standard form of digital audio in computers, compact discs, digital telephony and other digital audio applications. In a PCM stream, the amplitude of the analog signal is sampled regularly at uniform intervals, and each sample is quantized to the nearest value within a range of digital steps.

Linear pulse-code modulation (LPCM) is a specific type of PCM where the quantization levels are linearly uniform. This is in contrast to PCM encodings where quantization levels vary as a function of amplitude (as with the A-law algorithm or the μ -law algorithm). Though PCM is a more general term, it is often used to describe data encoded as LPCM.

A PCM stream has two basic properties that determine the stream's fidelity to the original analog signal: the sampling rate, which is the number of times per second that samples are taken; and the bit depth, which determines the number of possible digital values that can be used to represent each sample.

Differential Pulse Code Modulation

Differential pulse-code modulation (DPCM) is a signal encoder that uses the baseline of pulse-code modulation (PCM) but adds some functionalities based on the prediction of the samples of the signal. The input can be an analog signal or a digital signal.

If the input is a continuous-time analog signal, it needs to be sampled first so that a discrete-time signal is the input to the DPCM encoder.

Option 1: take the values of two consecutive samples; if they are analog samples, quantize them; calculate the difference between the first one and the next; the output is the difference, and it can be further entropy coded.

Option 2: instead of taking a difference relative to a previous input sample, take the difference relative to the output of a local model of the decoder process; in this option, the difference can be quantized, which allows a good way to incorporate a controlled loss in the encoding.

Applying one of these two processes, short-term redundancy (positive correlation of nearby values) of the signal is eliminated; compression ratios on the order of 2 to 4 can be achieved if differences are subsequently entropy coded, because the entropy of the

difference signal is much smaller than that of the original discrete signal treated as independent samples.

DPCM was invented by C. Chapin Cutler at Bell Labs in 1950; his patent includes both methods.

1. The encoder performs the function of differentiation; a quantizer precedes the differencing of adjacent quantized samples; the decoder is an accumulator, which if correctly initialized exactly recovers the quantized signal.
2. The incorporation of the decoder inside the encoder allows quantization of the differences, including nonlinear quantization, in the encoder, as long as an approximate inverse quantizer is used appropriately in the receiver. When the quantizer is uniform, the decoder regenerates the differences implicitly, as in this simple diagram that Cutler showed:

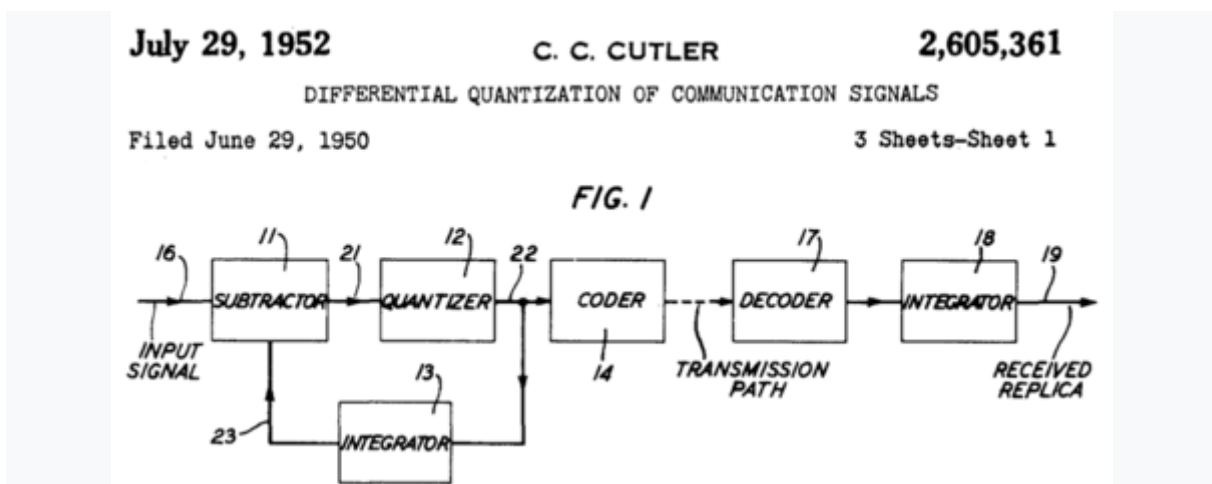

ASK

Amplitude-shift keying (ASK) is a form of amplitude modulation that represents digital data as variations in the amplitude of a carrier wave. In an ASK system, the binary symbol 1 is represented by transmitting a fixed-amplitude carrier wave and fixed frequency for a bit duration of T seconds. If the signal value is 1 then the carrier signal will be transmitted; otherwise, a signal value of 0 will be transmitted.

Any digital modulation scheme uses a finite number of distinct signals to represent digital data. ASK uses a finite number of amplitudes, each assigned a unique pattern of binary digits. Usually, each amplitude encodes an equal number of bits. Each pattern of bits forms the symbol that is represented by the particular amplitude. The demodulator,

which is designed specifically for the symbol-set used by the modulator, determines the amplitude of the received signal and maps it back to the symbol it represents, thus recovering the original data. Frequency and phase of the carrier are kept constant.

FSK

Frequency-shift keying (FSK) is a frequency modulation scheme in which digital information is transmitted through discrete frequency changes of a carrier signal. The technology is used for communication systems such as amateur radio, caller ID and emergency broadcasts. The simplest FSK is binary FSK (BFSK). BFSK uses a pair of discrete frequencies to transmit binary (0s and 1s) information. With this scheme, the "1" is called the mark frequency and the "0" is called the space frequency.

PSK

Phase-shift keying (PSK) is a digital modulation process which conveys data by changing (modulating) the phase of a reference signal (the carrier wave). The modulation occurs by varying the sine and cosine inputs at a precise time. It is widely used for wireless LANs, RFID and Bluetooth communication.

Any digital modulation scheme uses a finite number of distinct signals to represent digital data. PSK uses a finite number of phases, each assigned a unique pattern of binary digits. Usually, each phase encodes an equal number of bits. Each pattern of bits forms the symbol that is represented by the particular phase. The demodulator, which is designed specifically for the symbol-set used by the modulator, determines the phase of the received signal and maps it back to the symbol it represents, thus recovering the original data. This requires the receiver to be able to compare the phase of the received signal to a reference signal – such a system is termed coherent (and referred to as CPSK).

QPSK

Sometimes this is known as quadriphase PSK, 4-PSK, or 4-QAM. (Although the root concepts of QPSK and 4-QAM are different, the resulting modulated radio waves are exactly the same.) QPSK uses four points on the constellation diagram, equispaced around a circle. With four phases, QPSK can encode two bits per symbol, shown in the diagram with Gray coding to minimize the bit error rate (BER) – sometimes misperceived as twice the BER of BPSK.

The mathematical analysis shows that QPSK can be used either to double the data rate compared with a BPSK system while maintaining the same bandwidth of the signal, or to maintain the data-rate of BPSK but halving the bandwidth needed. In this latter case, the BER of QPSK is exactly the same as the BER of BPSK – and deciding differently is a common confusion when considering or describing QPSK. The transmitted carrier can undergo numbers of phase changes.

Given that radio communication channels are allocated by agencies such as the Federal Communication Commission giving a prescribed (maximum) bandwidth, the advantage of QPSK over BPSK becomes evident: QPSK transmits twice the data rate in a given bandwidth compared to BPSK - at the same BER. The engineering penalty that is paid is that QPSK transmitters and receivers are more complicated than the ones for BPSK. However, with modern electronics technology, the penalty in cost is very moderate.

As with BPSK, there are phase ambiguity problems at the receiving end, and differentially encoded QPSK is often used in practice.

Spread Spectrum Techniques

In telecommunication and radio communication, spread-spectrum techniques are methods by which a signal (e.g., an electrical, electromagnetic, or acoustic signal) generated with a particular bandwidth is deliberately spread in the frequency domain, resulting in a signal with a wider bandwidth. These techniques are used for a variety of reasons, including the establishment of secure communications, increasing resistance to natural interference, noise and jamming, to prevent detection, and to limit power flux density (e.g., in satellite down links).

Frequency hopping Spread Spectrum

Frequency-hopping spread spectrum (FHSS) is a method of transmitting radio signals by rapidly switching a carrier among many frequency channels, using a pseudorandom sequence known to both transmitter and receiver. It is used as a multiple access method in the code division multiple access (CDMA) scheme frequency-hopping code division multiple access (FH-CDMA).

FHSS is a wireless technology that spreads its signal over rapidly changing frequencies. Each available frequency band is divided into sub-frequencies. Signals rapidly change

("hop") among these in a pre-determined order. Interference at a specific frequency will only affect the signal during that short interval. FHSS can, however, cause interference with adjacent direct-sequence spread spectrum (DSSS) systems. A sub-type of FHSS used in Bluetooth wireless data transfer is adaptive frequency hopping spread spectrum (AFH).